

Q.TÀ SCATOLA PACKAGE Q.TY	300
PESO SCATOLA PACKAGE WEIGHT	14 kg 30.87 lb
DIMENSIONI SCATOLA PACKAGE DIMENSION	42x29x52 cm 16.53x11.41x20.47 inch

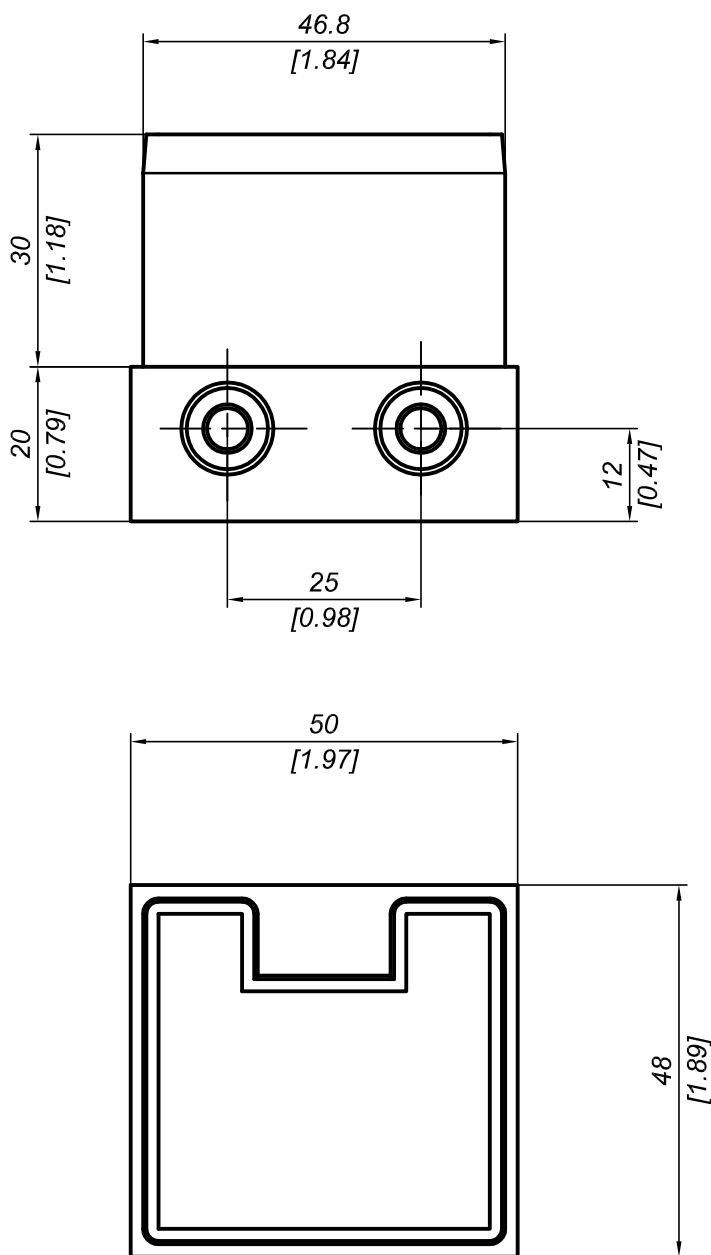

DESCRIZIONE
GIUNTO IN ALLUMINIO PER OMEGA 50 mm

DESCRIPTION
ALUMINIUM OMEGA JOINT FOR OMEGA 50 mm

MATERIALE MATERIAL	ALLUMINIO (AB 46100) ALUMINIUM (AB 46100)	TRATTAMENTO TREATMENT	--
-----------------------	--	--------------------------	----

PESO TEORICO THEORETICAL WEIGHT	-- kg -- lb	NORMA TOLLERANZA STANDARD TOLLERANCE	--
------------------------------------	----------------	---	----

PRO-LAM s.r.l.
ALLUMINIO

SCALA SCALE	1:1	DATA DATE	28/08/2013
----------------	-----	--------------	------------

CODICE CODE	A 50/45JP	FORMATO SIZE	A4	
----------------	-----------	-----------------	----	--

Questo disegno è di proprietà riservata alla ditta PRO-LAM ALLUMINIO s.r.l. A termini di legge è assolutamente vietato riprodurre o comunicare a terzi il contenuto del presente disegno. This drawing is a property of PRO-LAM ALLUMINIO s.r.l. This drawing shall not be reproduced or released to others except as otherwise authorized by PRO-LAM ALLUMINIO s.r.l.