

Q.TÀ SCATOLA PACKAGE Q.TY	300
PESO SCATOLA PACKAGE WEIGHT	14 kg 30.87 lb
DIMENSIONI SCATOLA PACKAGE DIMENSION	42x29x52 cm 16.53x11.41x20.47 inch

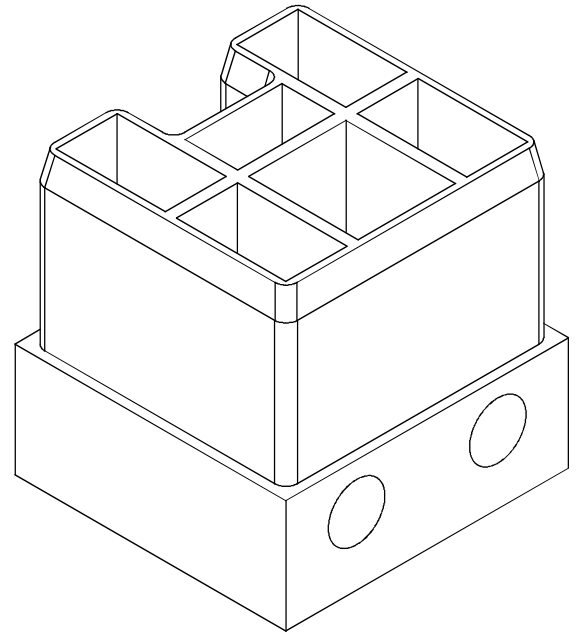
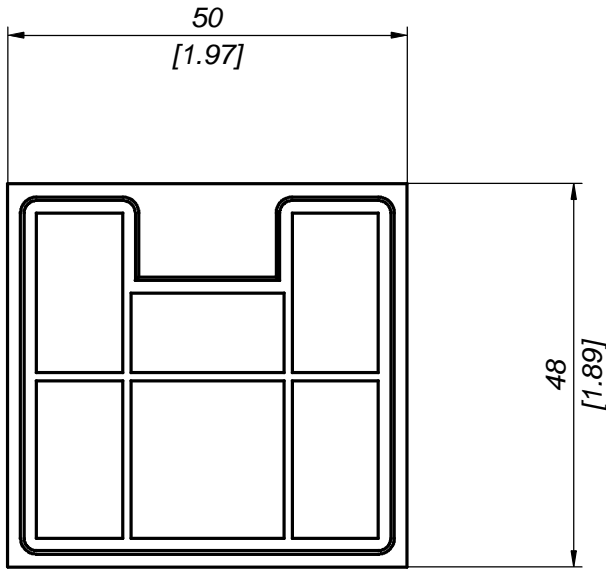
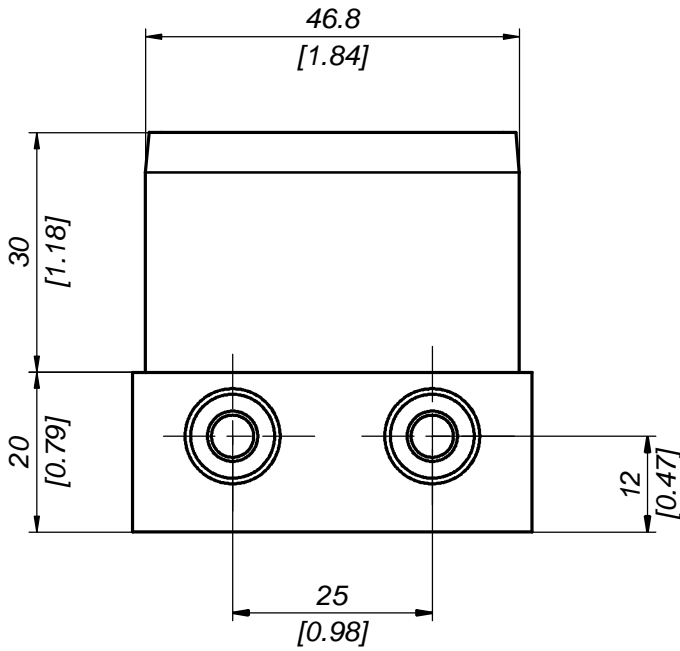

DESCRIZIONE
GIUNTO IN NYLON PER OMEGA 50 mm

DESCRIPTION
OMEGA JOINT FOR OMEGA 50 mm

MATERIALE
MATERIAL
PA6+30%G.F.

TRATTAMENTO
TREATMENT
--

PESO TEORICO
THEORETICAL WEIGHT
-- kg
-- lb

NORMA TOLLERANZA
STANDARD TOLLERANCE
--

PRO-LAM s.r.l.
ALLUMINIO

SCALA
SCALE
1:1

DATA
DATE
2009/07/18

CODICE
CODE
N 50/45JP

FORMATO
SIZE
A4

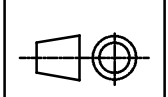

Questo disegno è di proprietà riservata alla ditta PRO-LAM ALLUMINIO s.r.l. A termini di legge è assolutamente vietato riprodurre o comunicare a terzi il contenuto del presente disegno. This drawing is a property of PRO-LAM ALLUMINIO s.r.l. This drawing shall not be reproduced or released to others except as otherwise authorized by PRO-LAM ALLUMINIO s.r.l.