

Q.TÀ SCATOLA PACKAGE Q.TY	50
PESO SCATOLA PACKAGE WEIGHT	14 kg 30.87 lbs
DIMENSIONI SCATOLA PACKAGE DIMENSION	33x47x30 cm 12.99x8.5x11.81 inches

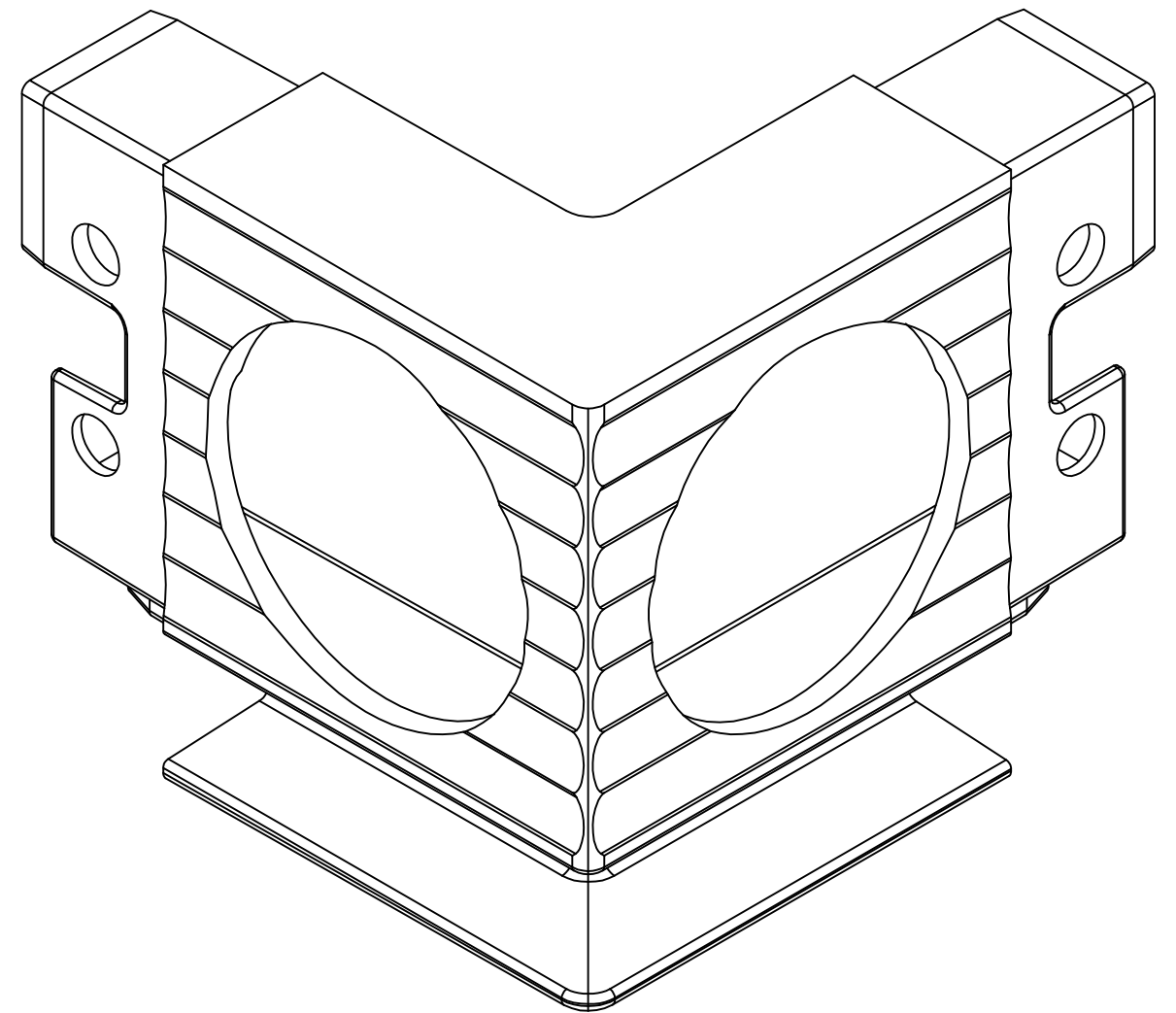
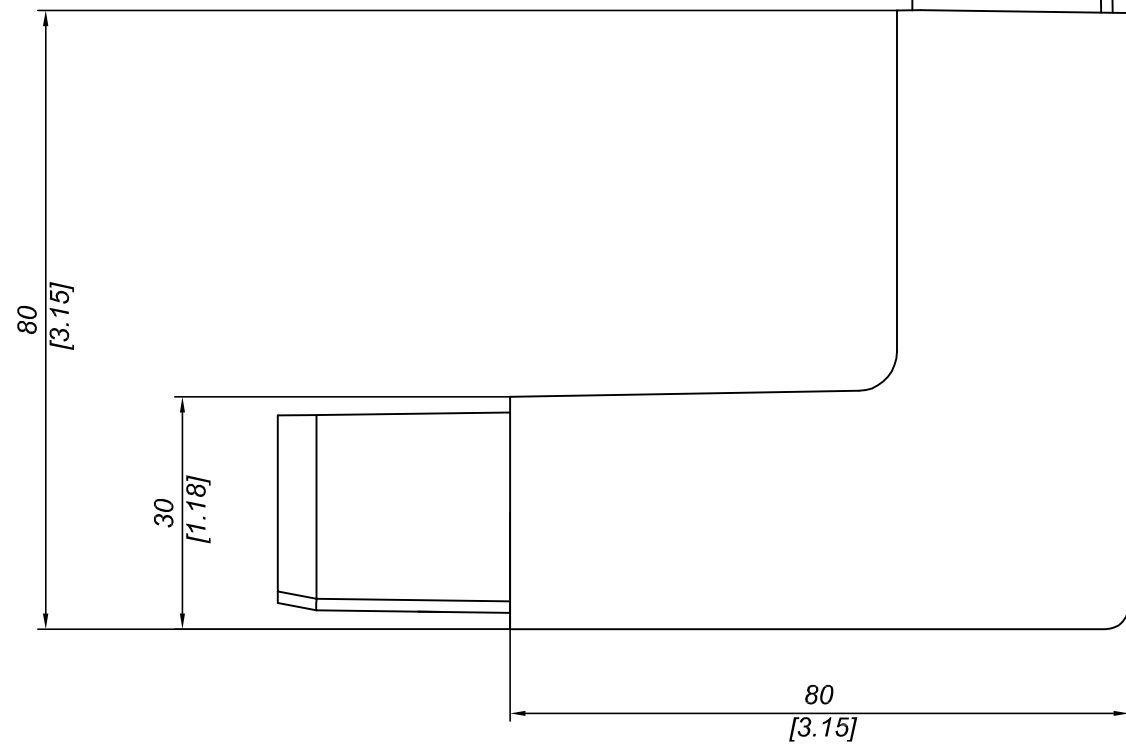
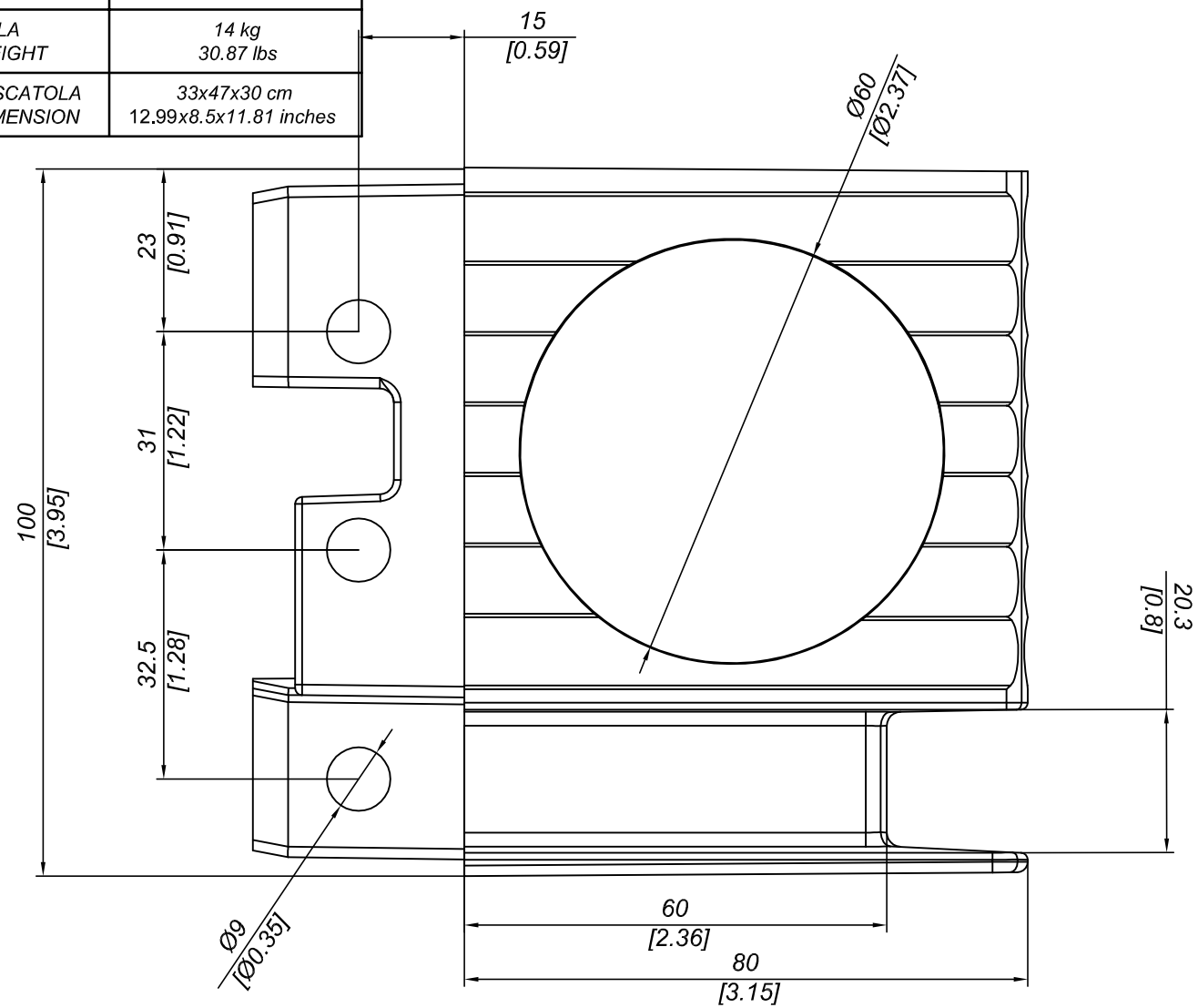

DESCRIZIONE ANGOLI ALLUMINIO PER BAS 100/30 TL		PRO-LAM s.r.l. ALLUMINIO	
DESCRIPTION ALUMINIUM JOINT FOR BAS 100/30 TL			
MATERIALE MATERIAL	ALLUMINIO (AB 46100) ALUMINIUM (AB 46100)	TRATTAMENTO TREATMENT	--
PESO TEORICO THEORETICAL WEIGHT	-- kg -- lb	NORMA TOLLERANZA STANDARD TOLERANCE	--
		SCALA SCALE	1:1
		DATA DATE	2009/07/18
		CODICE CODE	A100
		FORMATO SIZE	A3

Questo disegno è di proprietà riservata alla ditta PRO-LAM ALLUMINIO s.r.l. A termini di legge è assolutamente vietato riprodurre o comunicare a terzi il contenuto del presente disegno. This drawing is a property of PRO-LAM ALLUMINIO s.r.l. This drawing shall not be reproduced or released to others except as otherwise authorized by PRO-LAM ALLUMINIO s.r.l.