

| | |
|---|------------------|
| Q.TÀ SCATOLA PACKAGE Q.TY | 50 |
| PESO SCATOLA PACKAGE WEIGHT | -- kg -- lb |
| DIMENSIONI SCATOLA PACKAGE DIMENSION | -- cm -- inch |

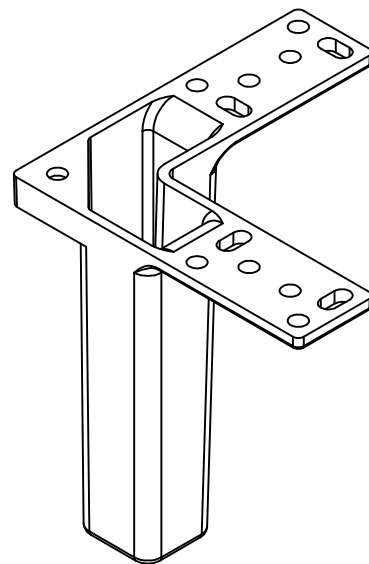

| | |
|---|---|
| DESCRIZIONE PIEDINO IN ALLUMINIO | |
| DESCRIPTION ALUMINIUM FOOT | |
| MATERIALE MATERIAL ALLUMINIO (AB 46100) ALUMINIUM (AB 46100) | TRATTAMENTO TREATMENT -- |
| PESO TEORICO THEORETICAL WEIGHT -- kg -- lb | NORMA TOLLERANZA STANDARD TOLLERANCE -- |

| | | | |
|--|--|--------------------------|----------------------------|
| | | SCALA SCALE 1:1 | DATA DATE 15/02/2012 |
| | | CODICE CODE A 100F | FORMATO SIZE A4 |

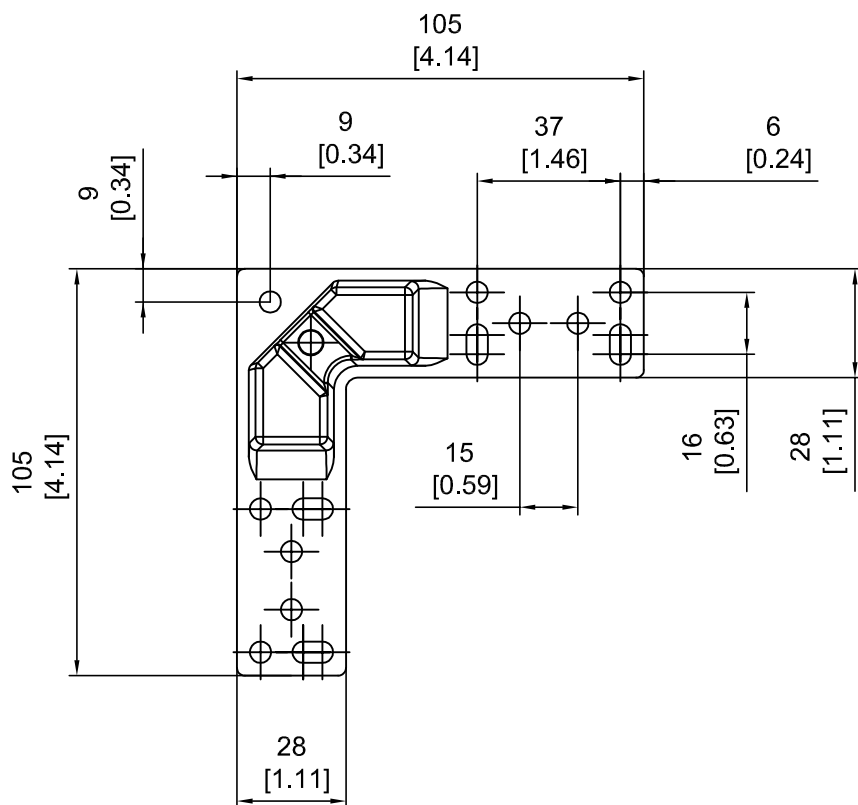
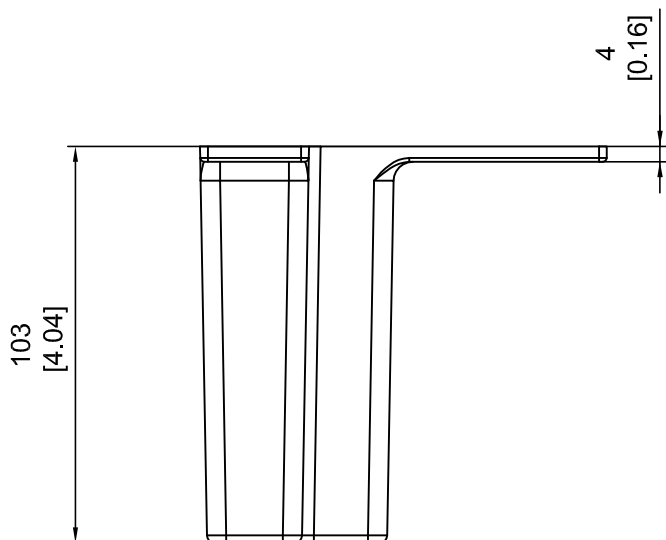
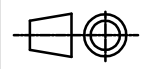

Questo disegno è di proprietà riservata alla ditta PRO-LAM ALLUMINIO s.r.l. A termini di legge è assolutamente vietato riprodurre o comunicare a terzi il contenuto del presente disegno.
 This drawing is a property of PRO-LAM ALLUMINIO s.r.l. This drawing shall not be reproduced or released to others except as otherwise authorized by PRO-LAM ALLUMINIO s.r.l.