

Q.TÀ SCATOLA PACKAGE Q.TY	100 pcs
PESO SCATOLA PACKAGE WEIGHT	8 kg 17.66 lb
DIMENSIONI SCATOLA PACKAGE DIMENSION	18x25x14 cm 7.09x9.84x5.51 inches

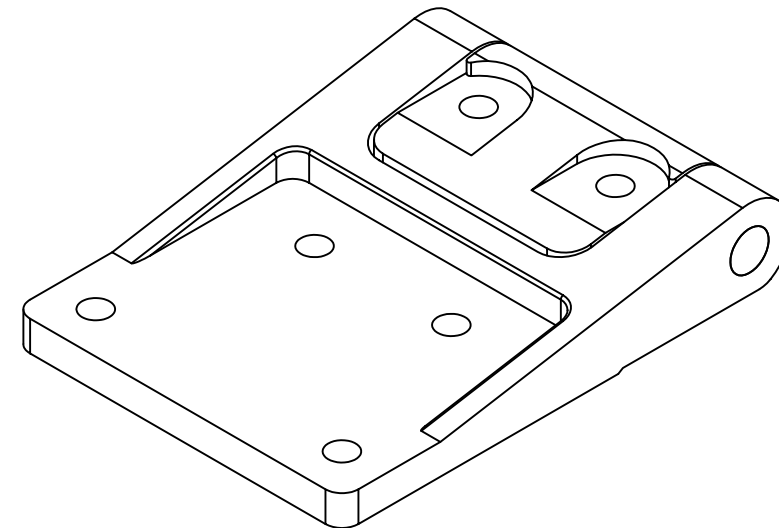
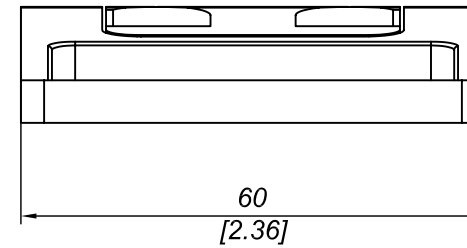
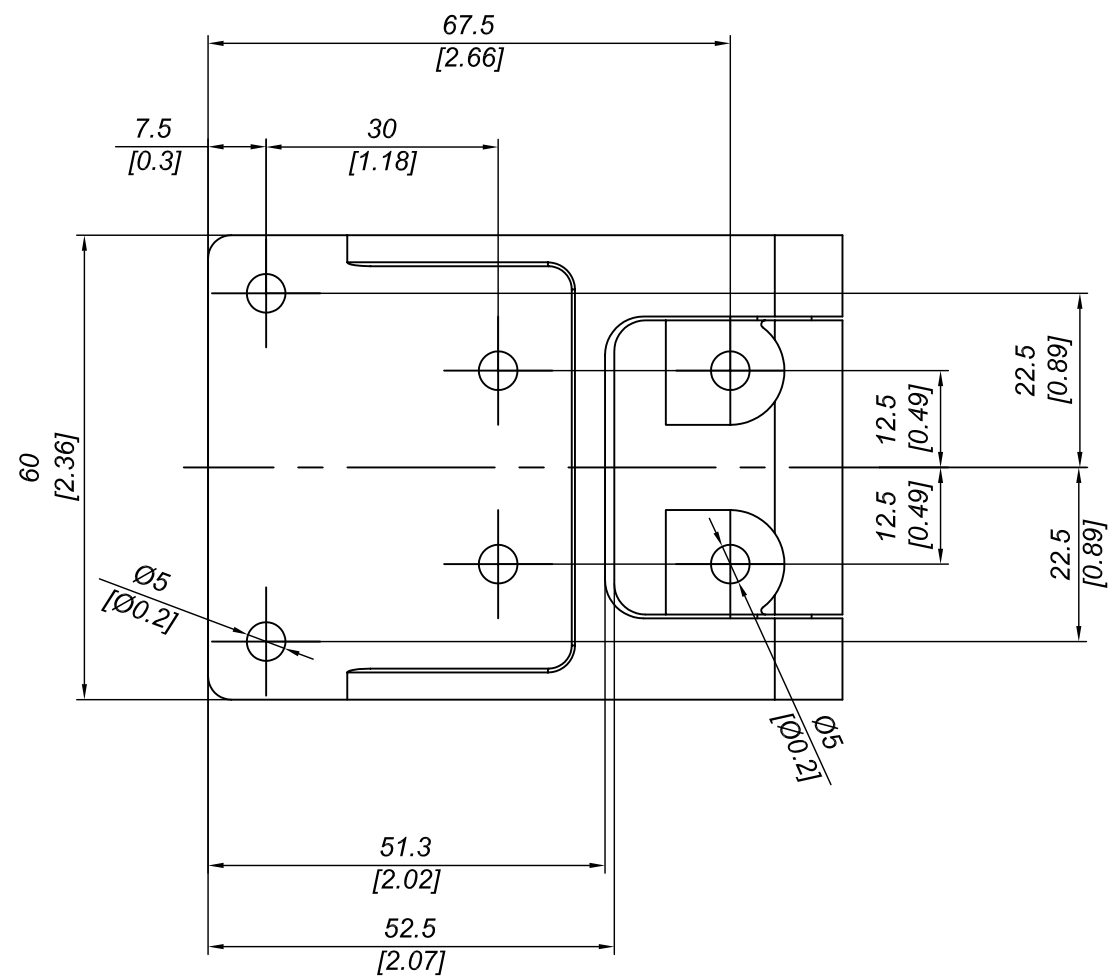
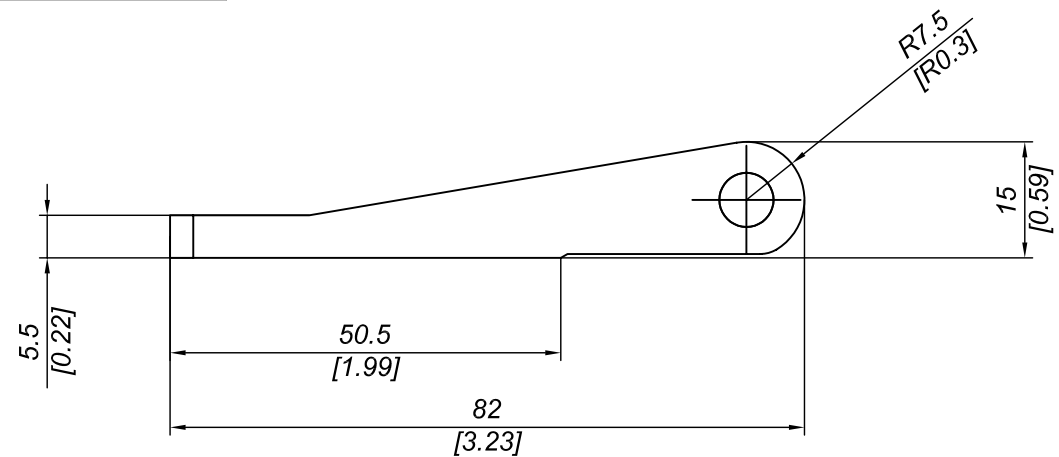

DESCRIZIONE CERNIERA A151		PRO-LAM s.r.l. ALLUMINIO	
DESCRIPTION ALUMINIUM HINGE A151			
MATERIALE MATERIAL	ALLUMINIO (AB 46100) ALUMINIUM (AB 46100)	TRATTAMENTO TREATMENT	VERNICIATURA: SILVER / NERA PAINTED: SILVER / BLACK
PESO TEORICO THEORETICAL WEIGHT		NORMA TOLLERANZA STANDARD TOLERANCE	
-- kg -- lb		--	
SCALA SCALE	1:1	DATA DATE	2009/07/18
CODICE CODE	A151	FORMATO SIZE	A3

Questo disegno è di proprietà riservata alla ditta PRO-LAM ALLUMINIO s.r.l. A termini di legge è assolutamente vietato riprodurre o comunicare a terzi il contenuto del presente disegno. This drawing is a property of PRO-LAM ALLUMINIO s.r.l. This drawing shall not be reproduced or released to others except as otherwise authorized by PRO-LAM ALLUMINIO s.r.l.