

Q.TÀ SCATOLA PACKAGE Q.TY	50
PESO SCATOLA PACKAGE WEIGHT	8 kg 17.66 lb
DIMENSIONI SCATOLA PACKAGE DIMENSION	18x25x14 cm 7.08x9.84x5.51 inch

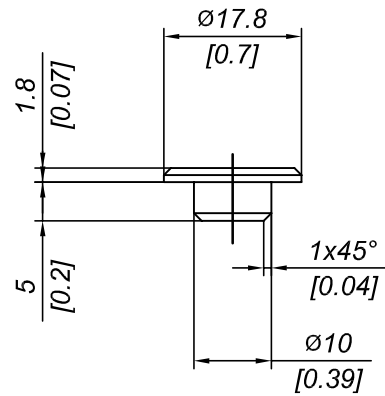

PA6+30% G.F.

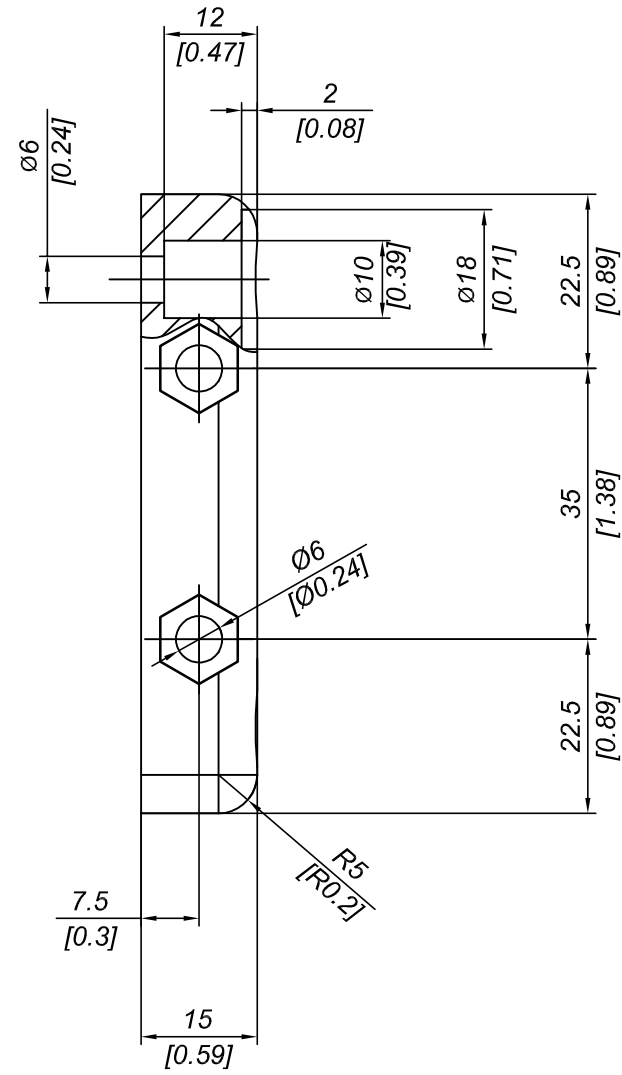
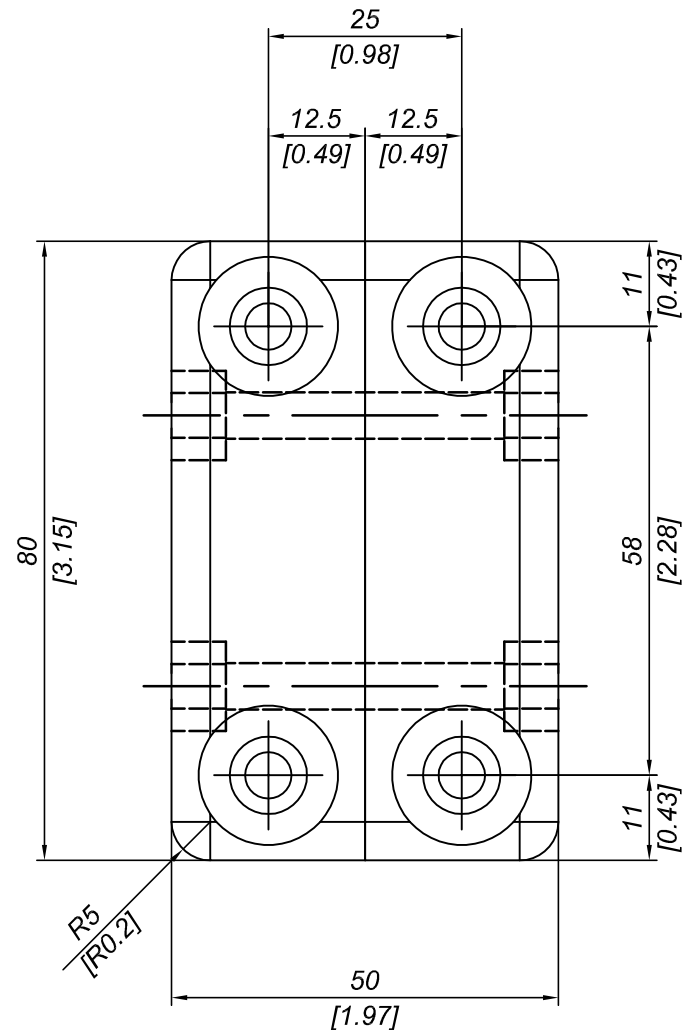
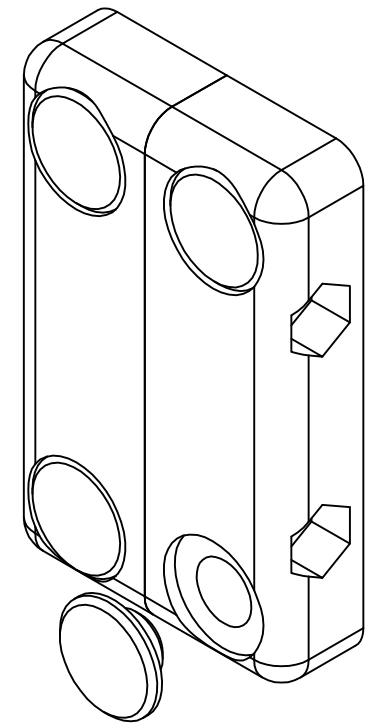

DESCRIZIONE BLOCCHETTI IN ALLUMINIO PER UNIONE UNITÀ		DESCRIZIONE ALUMINIUM CONNECTING BRACKET FOR UNIT SECTION	
MATERIALE MATERIAL	ALLUMINIO (AB 46100) ALUMINIUM (AB 46100)	TRATTAMENTO TREATMENT	SABBIATURA VERNICIATURA NERA SAND BLASTED PAINTED: BLACK
PESO TEORICO THEORETICAL WEIGHT	-- kg -- lb	NORMA TOLLERANZA STANDARD TOLLERANCE	--

PRO-LAM s.r.l.
ALLUMINIO

SCALA SCALE	1:1	DATA DATE	2009/07/18
CODICE CODE	ACB 80x50	FORMATO SIZE	A3

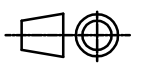

Questo disegno è di proprietà riservata alla ditta PRO-LAM ALLUMINIO s.r.l. A termini di legge è assolutamente vietato riprodurre o comunicare a terzi il contenuto del presente disegno. This drawing is a property of PRO-LAM ALLUMINIO s.r.l. This drawing shall not be reproduced or released to others except as otherwise authorized by PRO-LAM ALLUMINIO s.r.l.