

Q.TÀ SCATOLA PACKAGE Q.TY	90
PESO SCATOLA PACKAGE WEIGHT	16 kg 32.28 lbs
DIMENSIONI SCATOLA PACKAGE DIMENSION	22x35x22 cm 8.66x13.77x8.66 inches

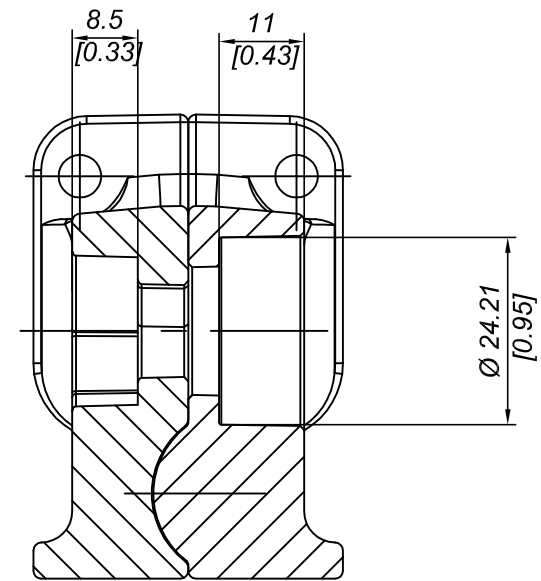

SEZIONE A-A

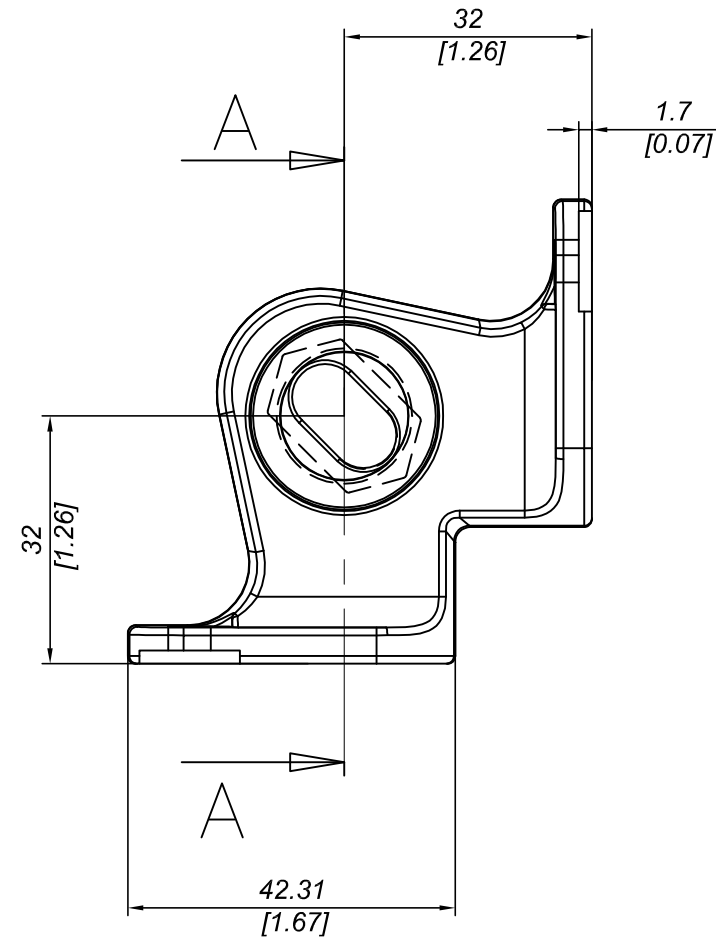
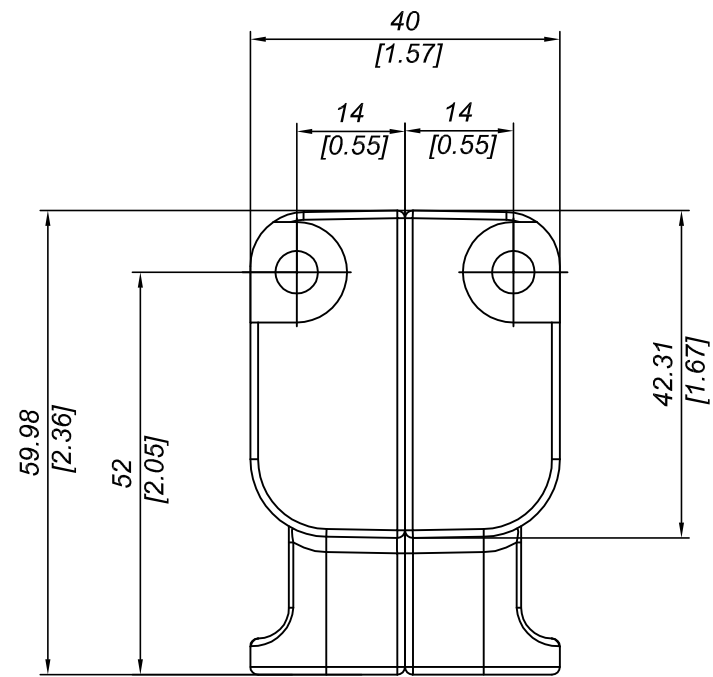
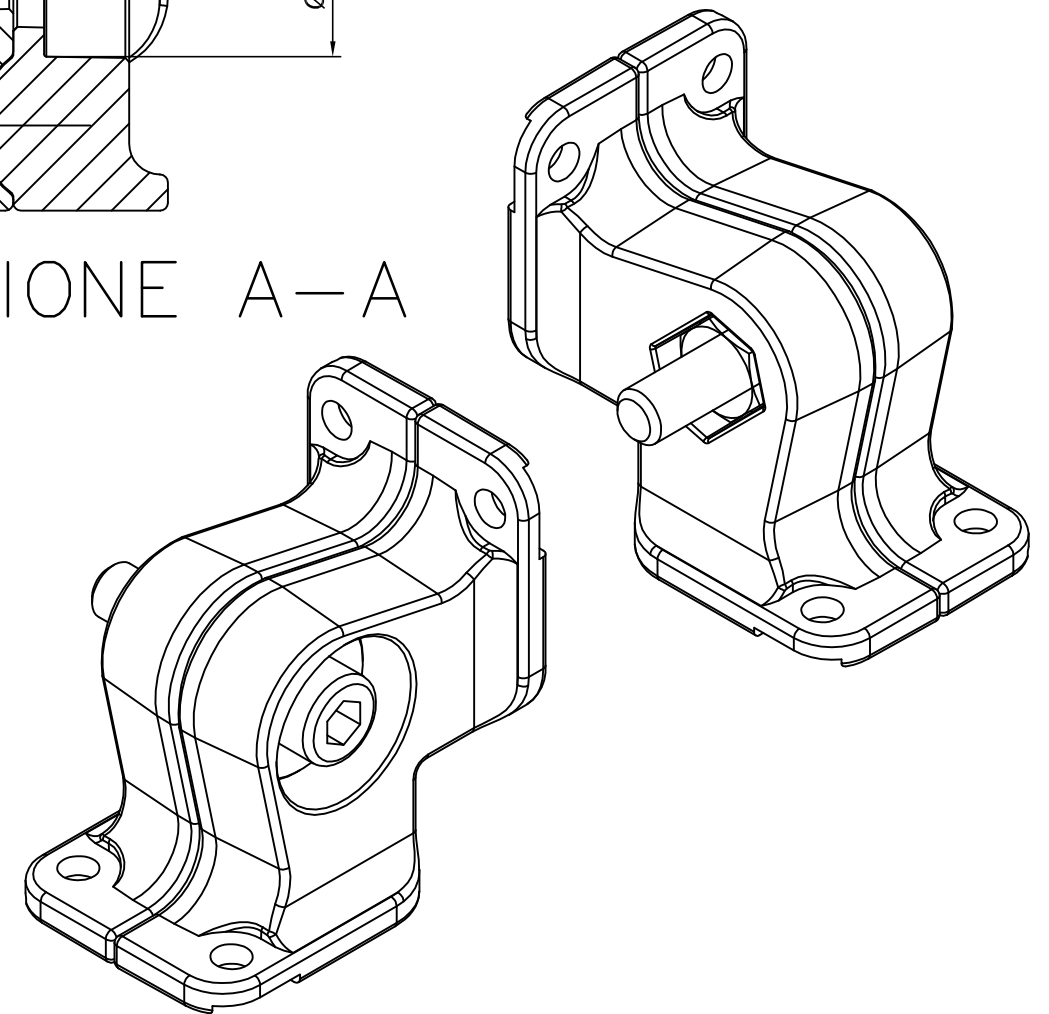
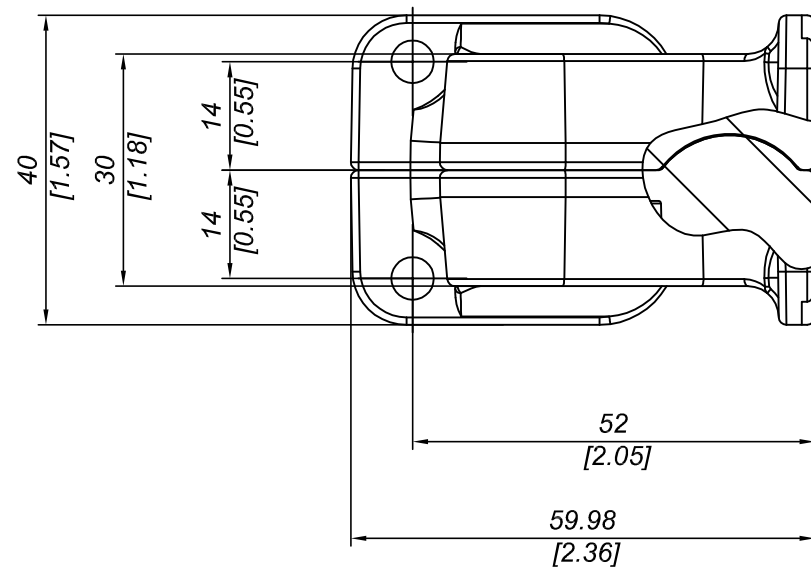

DESCRIZIONE SQUADRETTA IN ALLUMINIO							
DESCRIPTION ALUMINIUM CLAMP							
MATERIALE MATERIAL	ALLUMINIO (AB 46100) ALUMINIUM (AB 46100)	TRATTAMENTO TREATMENT	SABBIATURA SAND BLASTED	SCALA SCALE	1:1	DATA DATE	2009/07/18
PESO TEORICO THEORETICAL WEIGHT	-- kg/mt -- lbs/ft	NORMA TOLLERANZA STANDARD TOLERANCE	--	CODICE CODE	ACB-C1	FORMATO SIZE	A3

Questo disegno è di proprietà riservata alla ditta PRO-LAM ALLUMINIO s.r.l. A termini di legge è assolutamente vietato riprodurre o comunicare a terzi il contenuto del presente disegno. This drawing is a property of PRO-LAM ALLUMINIO s.r.l. This drawing shall not be reproduced or released to others except as otherwise authorized by PRO-LAM ALLUMINIO s.r.l.