

Q.TÀ SCATOLA PACKAGE Q.TY	50
PESO SCATOLA PACKAGE WEIGHT	14 kg 30.87 lbs
DIMENSIONI SCATOLA PACKAGE DIMENSION	18x25x14 cm 7.09x9.84x5.51 inches

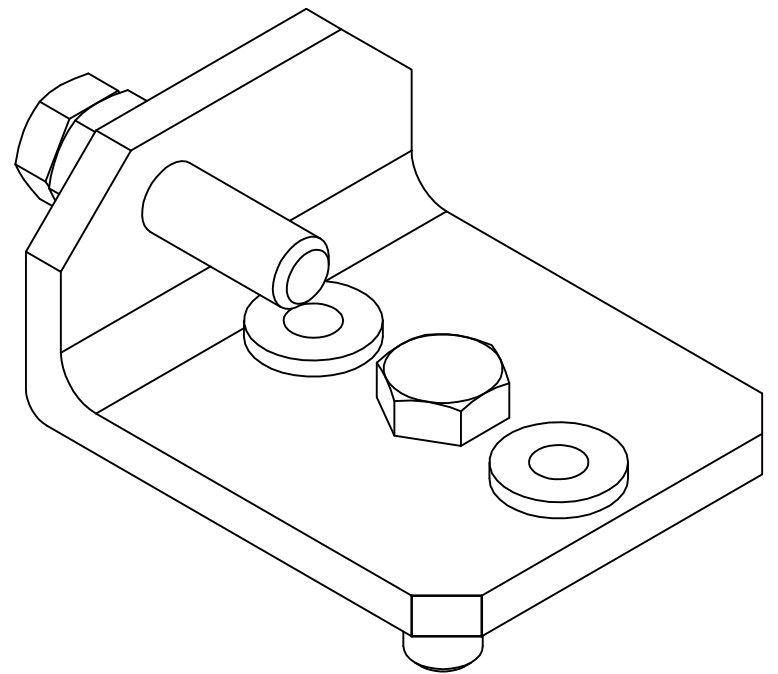
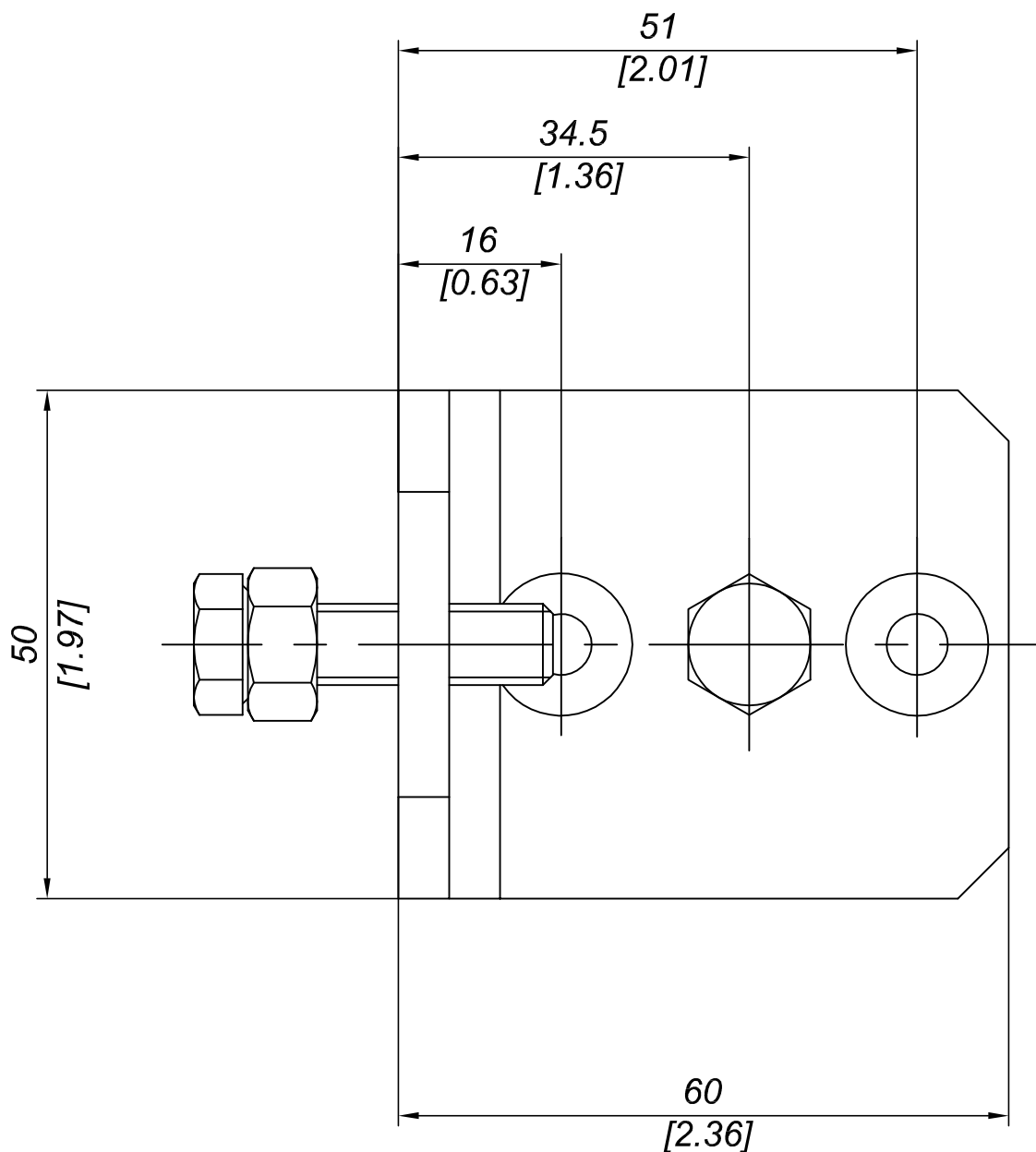
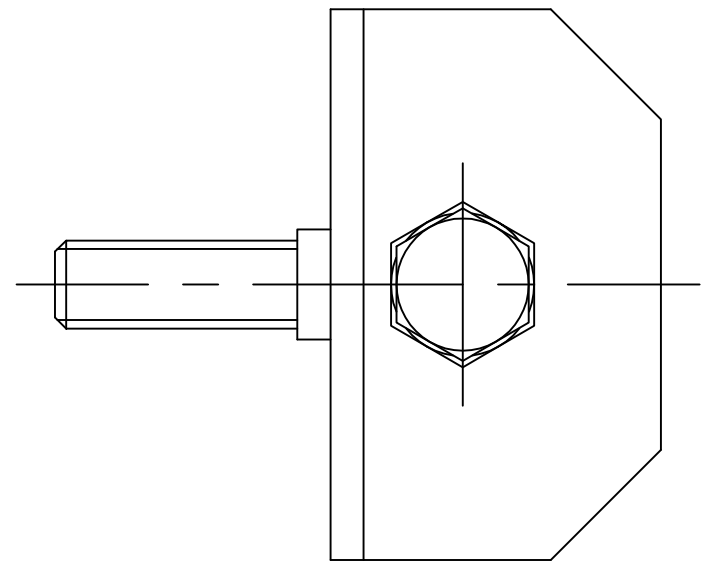
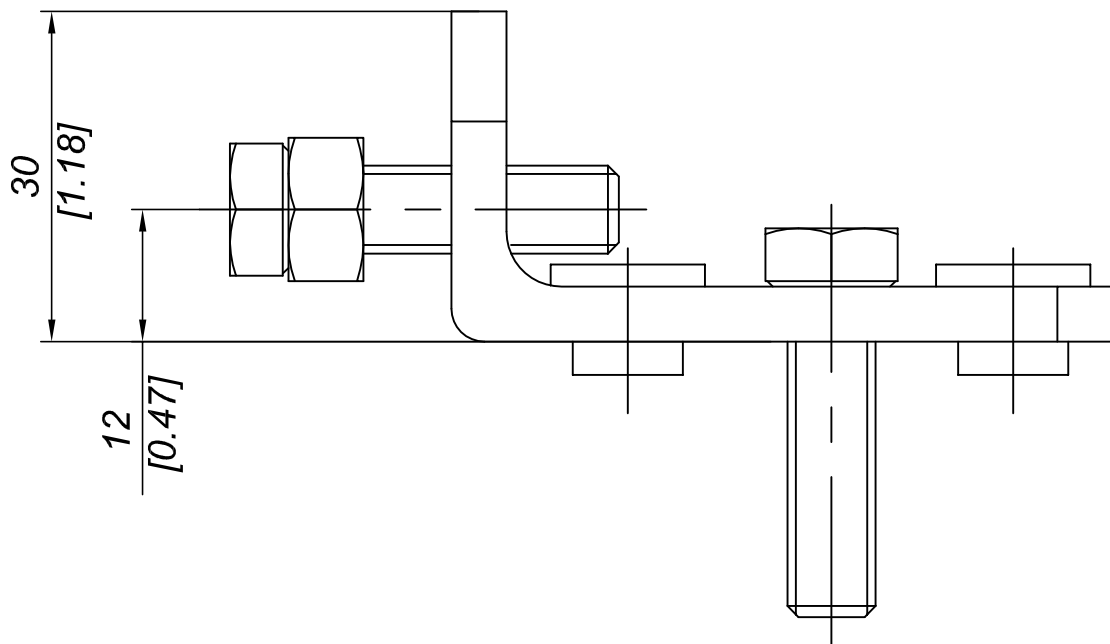

DESCRIZIONE

TENDICINGHIA

DESCRIPTION

BELT TENSIONER

MATERIALE
MATERIAL

**TROPICALIZED
STEEL**

TRATTAMENTO
TREATMENT

--

PESO TEORICO
THEORETICAL WEIGHT

-- kg
-- lbs

NORMA TOLLERANZA
STANDARD TOLERANCE

--

SCALA
SCALE

1:1

DATA
DATE

2009/07/18

CODICE
CODE

DN 400-800

FORMATO
SIZE

A4

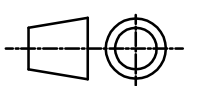

PRO-LAM s.r.l.
ALLUMINIO

Questo disegno è di proprietà riservata alla ditta PRO-LAM ALLUMINIO s.r.l. A termini di legge è assolutamente vietato riprodurre o comunicare a terzi il contenuto del presente disegno.
This drawing is a property of PRO-LAM ALLUMINIO s.r.l. This drawing shall not be reproduced or released to others except as otherwise authorized by PRO-LAM ALLUMINIO s.r.l.