

Q.TÀ SCATOLA PACKAGE Q.TY	50
PESO SCATOLA PACKAGE WEIGHT	5 kg 1.025 lbs
DIMENSIONI SCATOLA PACKAGE DIMENSION	22x35x22 cm 8.66x13.78x8.66 inches

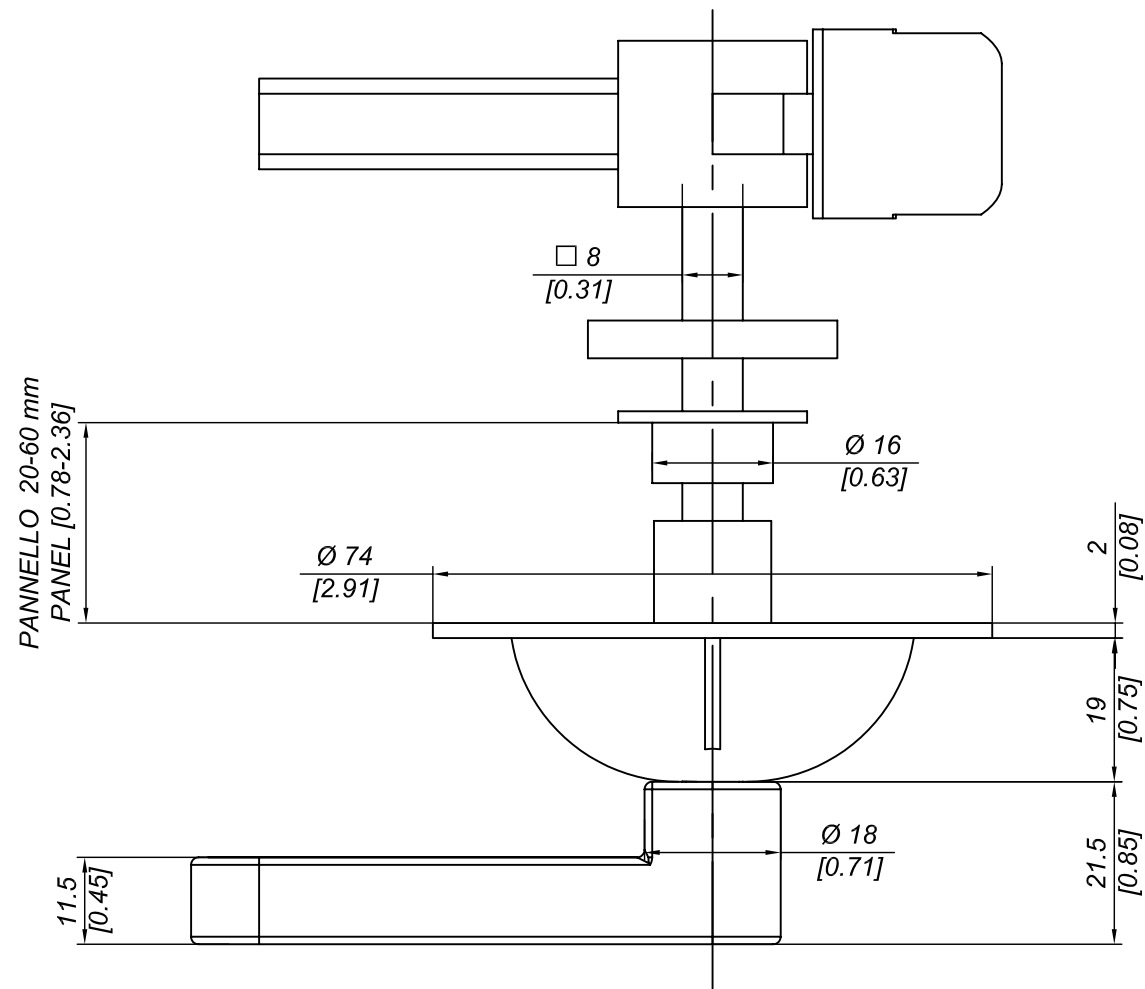

DESCRIZIONE POMOLO DI CHIUSURA CON CHIAVETTA ASPORTABILE PER PANNELLI: 20/25/45/50		DESCRIZIONE LOCK WITH REMOVABLE KEY FOR 20/25/45/50/60 mm PANELS	
MATERIALE MATERIAL PA6+30%G.F.	TRATTAMENTO TREATMENT --	SCALA SCALE 1:1	DATA DATE 2009/07/18
PESO TEORICO THEORETICAL WEIGHT -- kg -- lbs	NORMA TOLLERANZA STANDARD TOLERANCE --	CODICE CODE DN850/DN860	FORMATO SIZE A3

PRO-LAM s.r.l.
ALLUMINIO

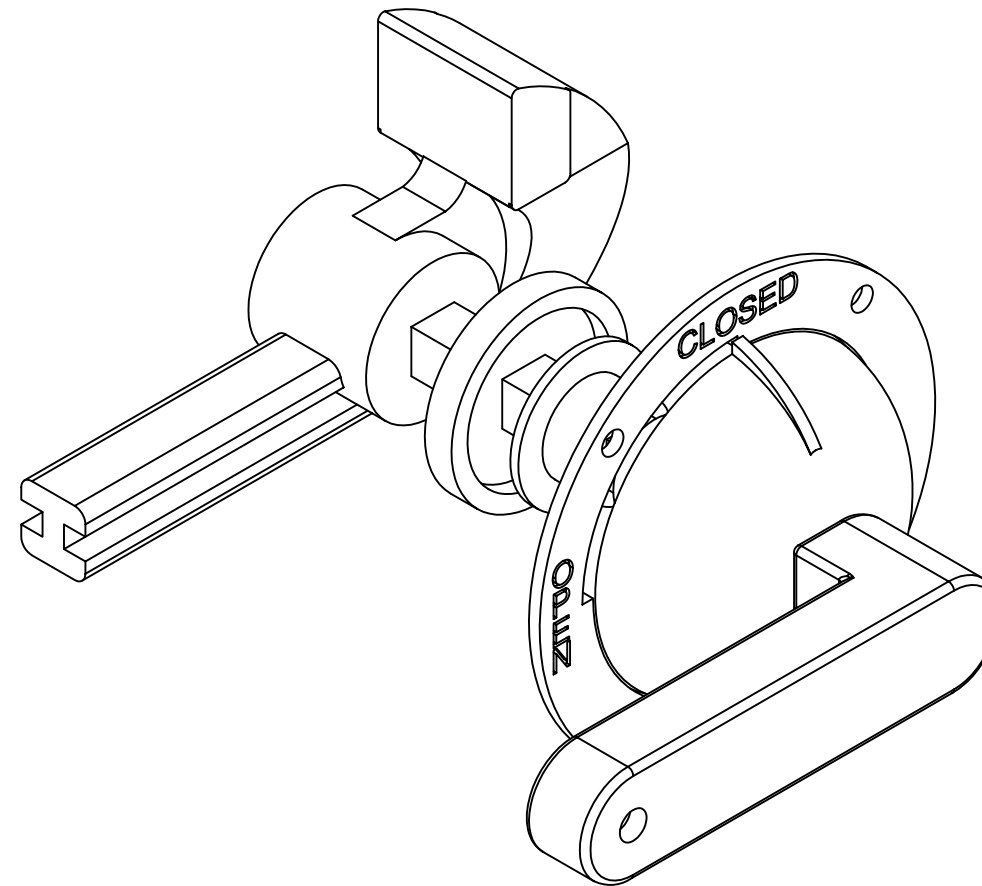
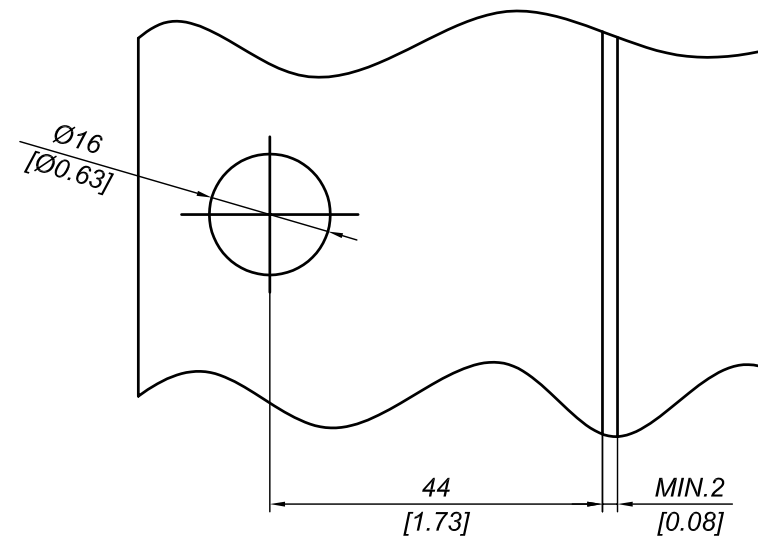
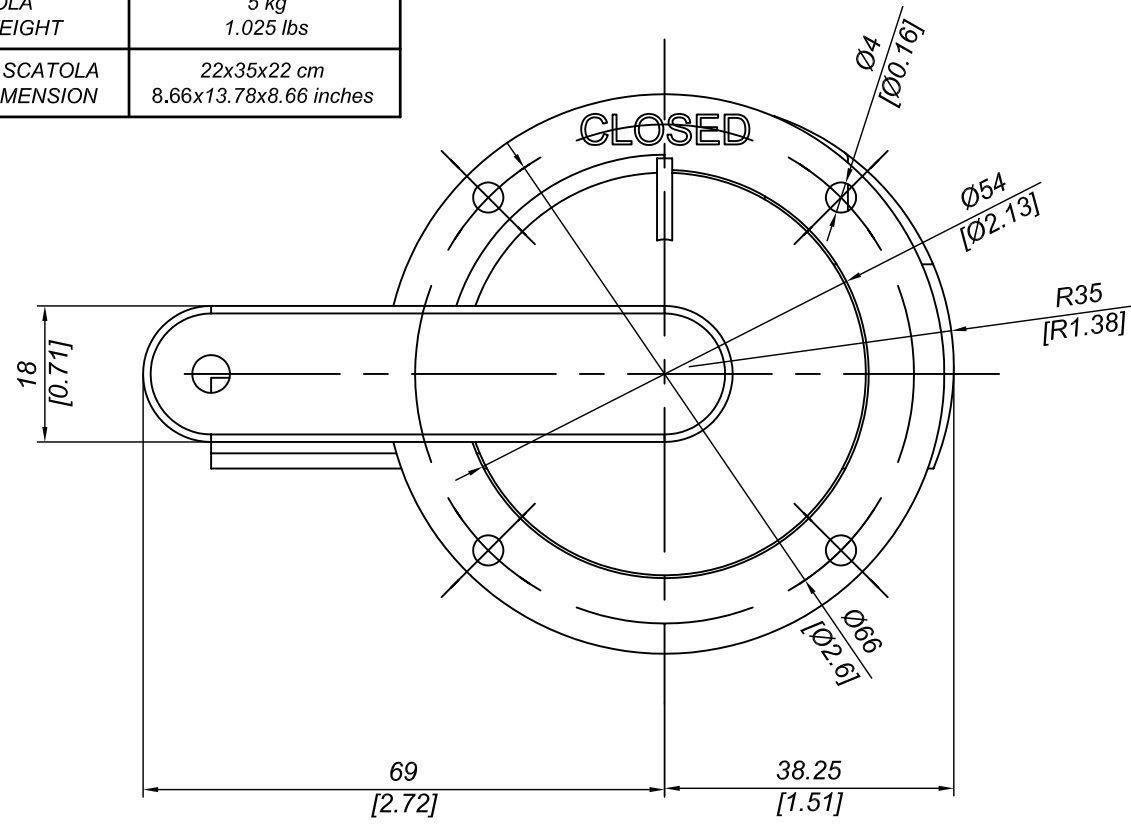

Questo disegno è di proprietà riservata alla ditta PRO-LAM ALLUMINIO s.r.l. A termini di legge è assolutamente vietato riprodurre o comunicare a terzi il contenuto del presente disegno. This drawing is a property of PRO-LAM ALLUMINIO s.r.l. This drawing shall not be reproduced or released to others except as otherwise authorized by PRO-LAM ALLUMINIO s.r.l.