

Q.TÀ SCATOLA PACKAGE Q.TY	22
PESO SCATOLA PACKAGE WEIGHT	7 kg 15.435 lbs
DIMENSIONI SCATOLA PACKAGE DIMENSION	22x35x22 cm 8.66x13.77x8.66 inches

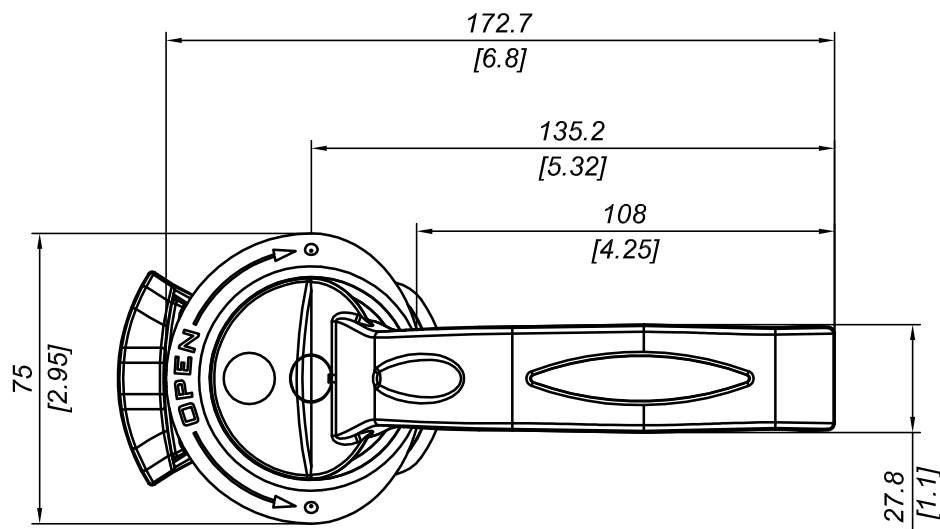

SCALA 1:2

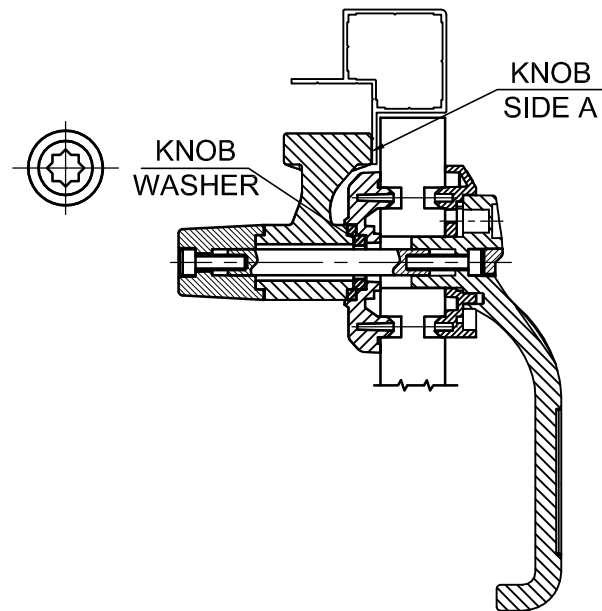

PANNELLO SINGOLA PIEGA
PROFILO STANDARD

SINGLE BEND PANEL
STANDARD PROFILE

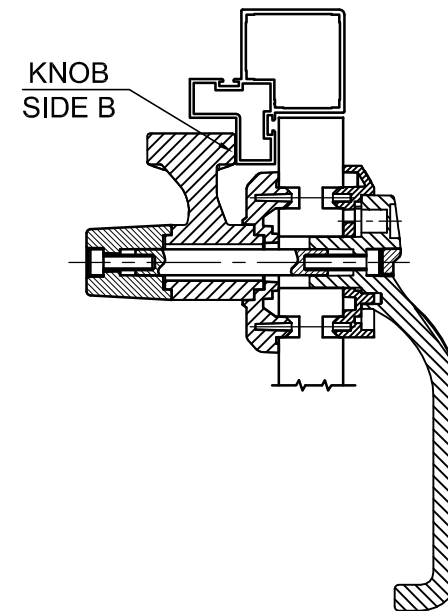

PANNELLO SINGOLA PIEGA
PROFILO DOPPIA CAMERA

SINGLE BEND PANEL
DOUBLE WALL PROFILE

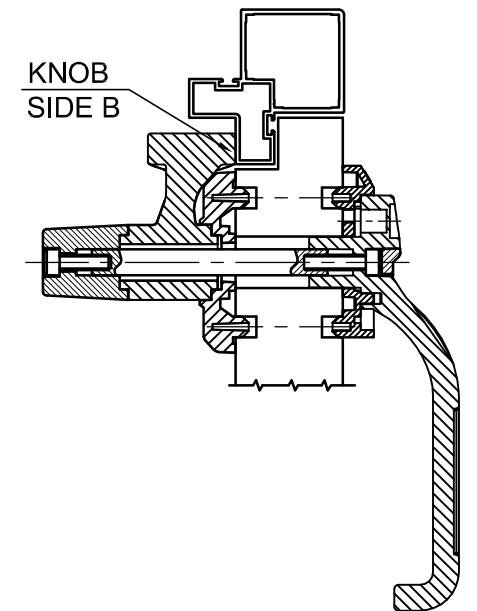

PANNELLO DOPPIA PIEGA
PROFILO DOPPIA CAMERA

DOUBLE BEND PANEL
DOUBLE WALL PROFILE

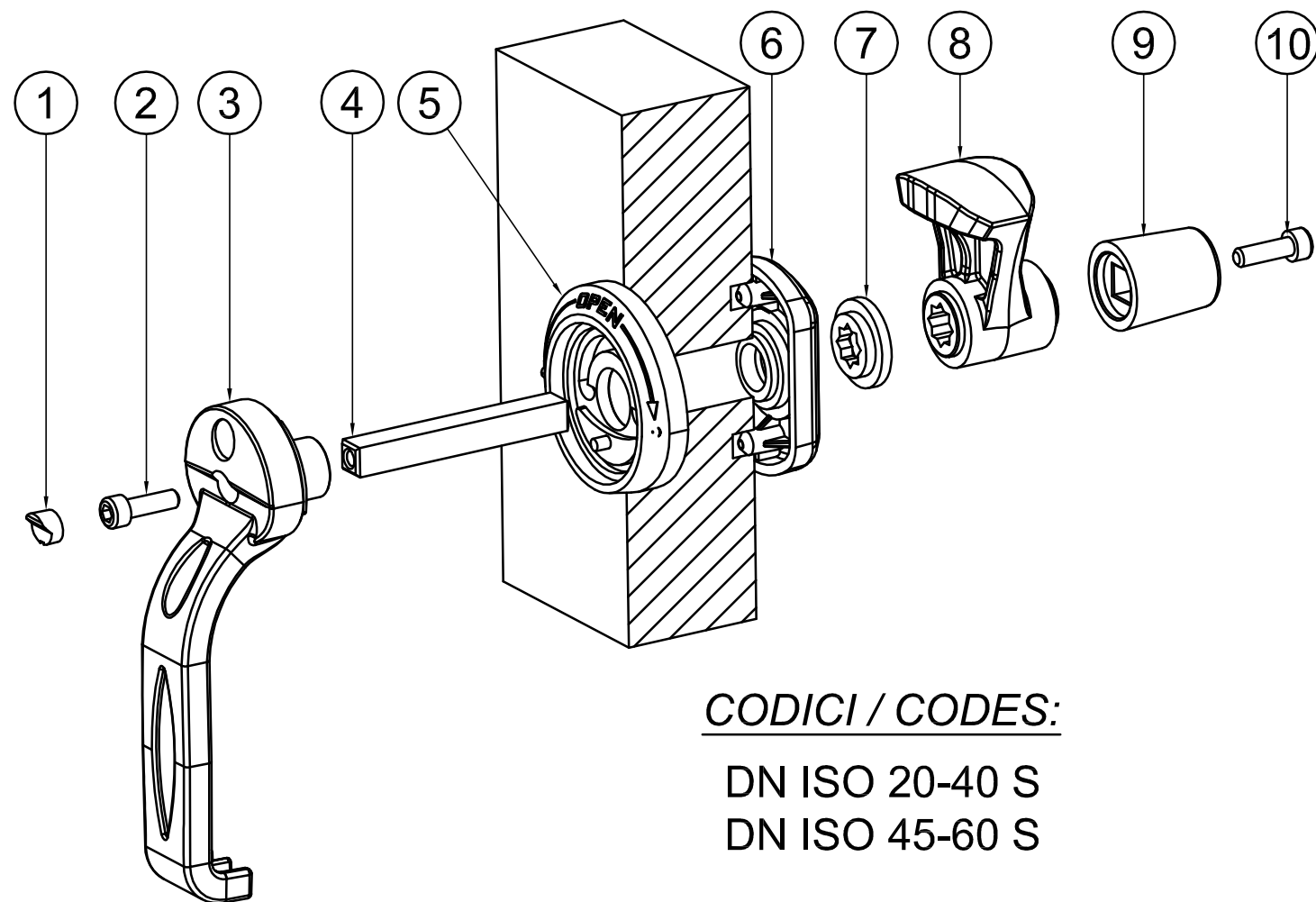

CODICI / CODES:

DN ISO 20-40 S
DN ISO 45-60 S

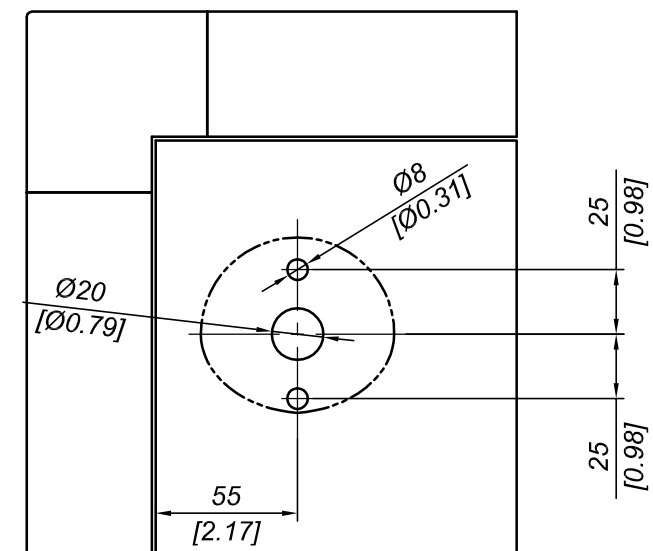

SCALA 1:3

DESCRIZIONE MANIGLIA IN NYLON	
DESCRIPTION NYLON HANDLE	
MATERIALE MATERIAL PA6 30 % FV_SV	TRATTAMENTO TREATMENT --
PESO TEORICO THEORETICAL WEIGHT -- kg -- lbs	NORMA TOLLERANZA STANDARD TOLERANCE --

PRO-LAM s.r.l.	
ALLUMINIO	
SCALA SCALE 1:1	DATA DATE 06/08/2009
CODICE CODE DN ISO_S	FORMATO SIZE A3

Questo disegno è di proprietà riservata alla ditta PRO-LAM ALLUMINIO s.r.l. A termini di legge è assolutamente vietato riprodurre o comunicare a terzi il contenuto del presente disegno. This drawing is a property of PRO-LAM ALLUMINIO s.r.l. This drawing shall not be reproduced or released to others except as otherwise authorized by PRO-LAM ALLUMINIO s.r.l.