

Q.TÀ SCATOLA PACKAGE Q.TY	500 m 1640,416 ft
PESO SCATOLA PACKAGE WEIGHT	10 kg 22,05 lbs
DIMENSIONI SCATOLA PACKAGE DIMENSION	51x51x35 cm 20,07x20,07x13,77 inches

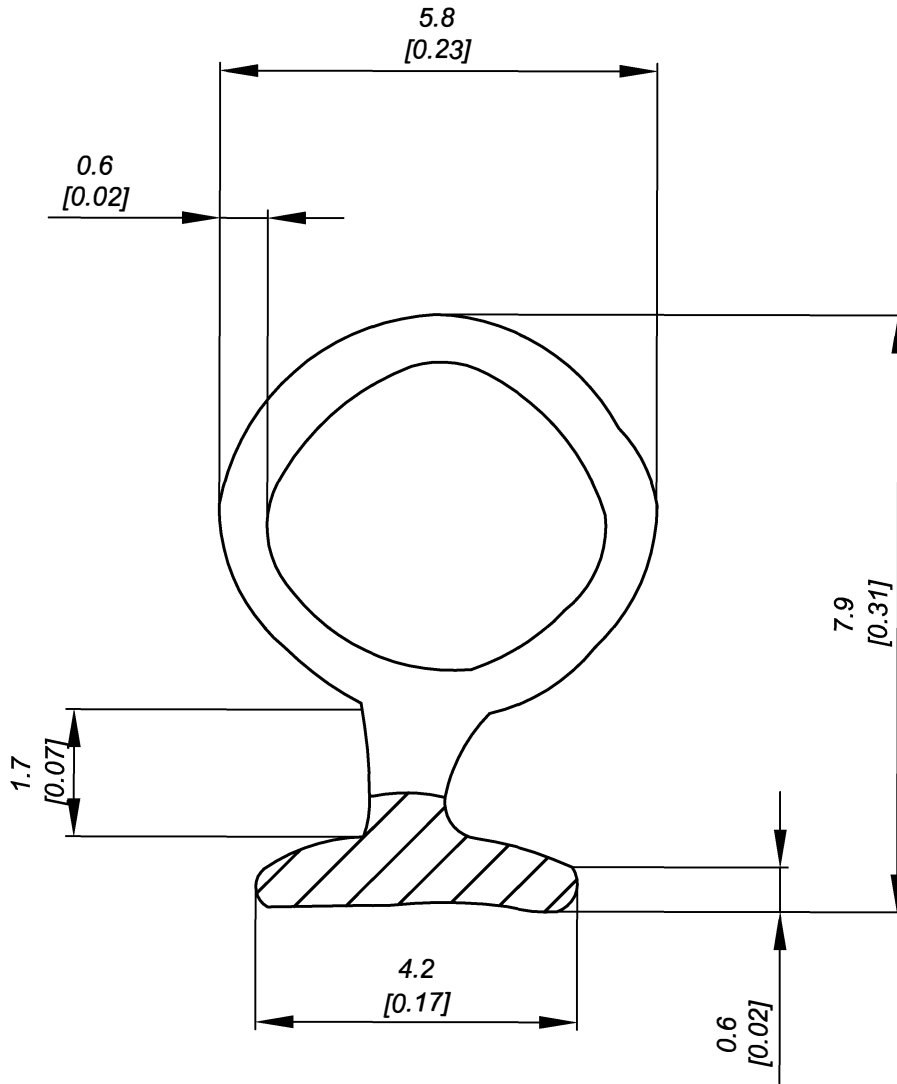

SCALA 1:1



DESCRIZIONE

GUARNIZIONE G0010

DESCRIPTION

GASKET G0010

**PRO-LAM** s.r.l.  
**ALLUMINIO**

MATERIALE  
MATERIAL TPE co-estruso  
TPE co-extruded

TRATTAMENTO  
TREATMENT None

SCALA  
SCALE 10:1

DATA  
DATE 16/01/2013

PESO TEORICO  
THEORETICAL WEIGHT -- kg  
-- lbs

NORMA TOLLERANZA  
STANDARD TOLERANCE  
DIN 16941

CODICE  
CODE G0010

FORMATO  
SIZE A4

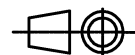

Questo disegno è di proprietà riservata alla ditta PRO-LAM ALLUMINIO s.r.l. A termini di legge è assolutamente vietato riprodurre o comunicare a terzi il contenuto del presente disegno.  
This drawing is a property of PRO-LAM ALLUMINIO s.r.l. This drawing shall not be reproduced or released to others except as otherwise authorized by PRO-LAM ALLUMINIO s.r.l.