

DESCRIZIONE

SPESSORE IN NYLON DA 4 mm

DESCRIPTION

NYLON SPACER 4 mm

MATERIALE  
MATERIAL PA6+30% F.V.  
PA6+30% G.F.

TRATTAMENTO  
TREATMENT --

SCALA  
SCALE 2:1

DATA  
DATE 27/04/2018

PESO TEORICO  
THEORETICAL WEIGHT -- kg  
-- lb

NORMA TOLLERANZA  
STANDARD TOLLERANCE --

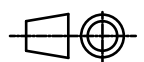

CODICE  
CODE NG001 G-50

FORMATO  
SIZE A4



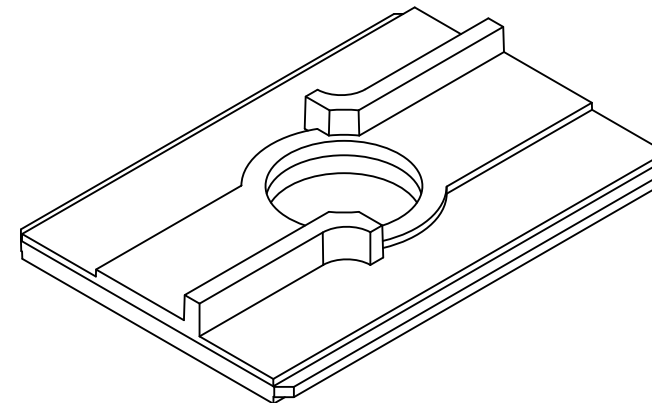
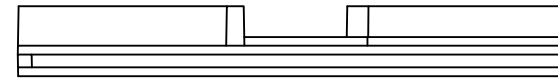
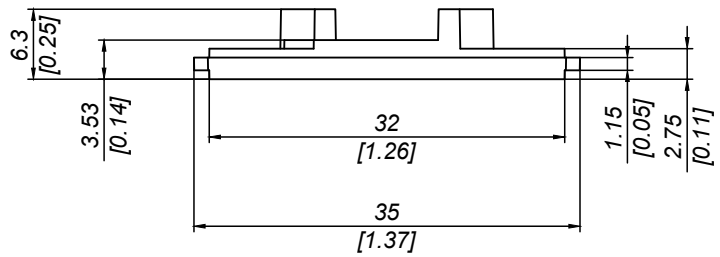

Questo disegno è di proprietà riservata alla ditta PRO-LAM ALLUMINIO s.r.l. A termini di legge è assolutamente vietato riprodurre o comunicare a terzi il contenuto del presente disegno.  
This drawing is a property of PRO-LAM ALLUMINIO s.r.l. This drawing shall not be reproduced or released to others except as otherwise authorized by PRO-LAM ALLUMINIO s.r.l.

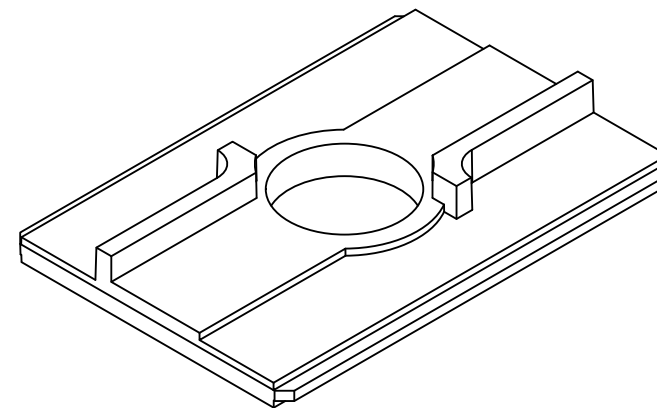
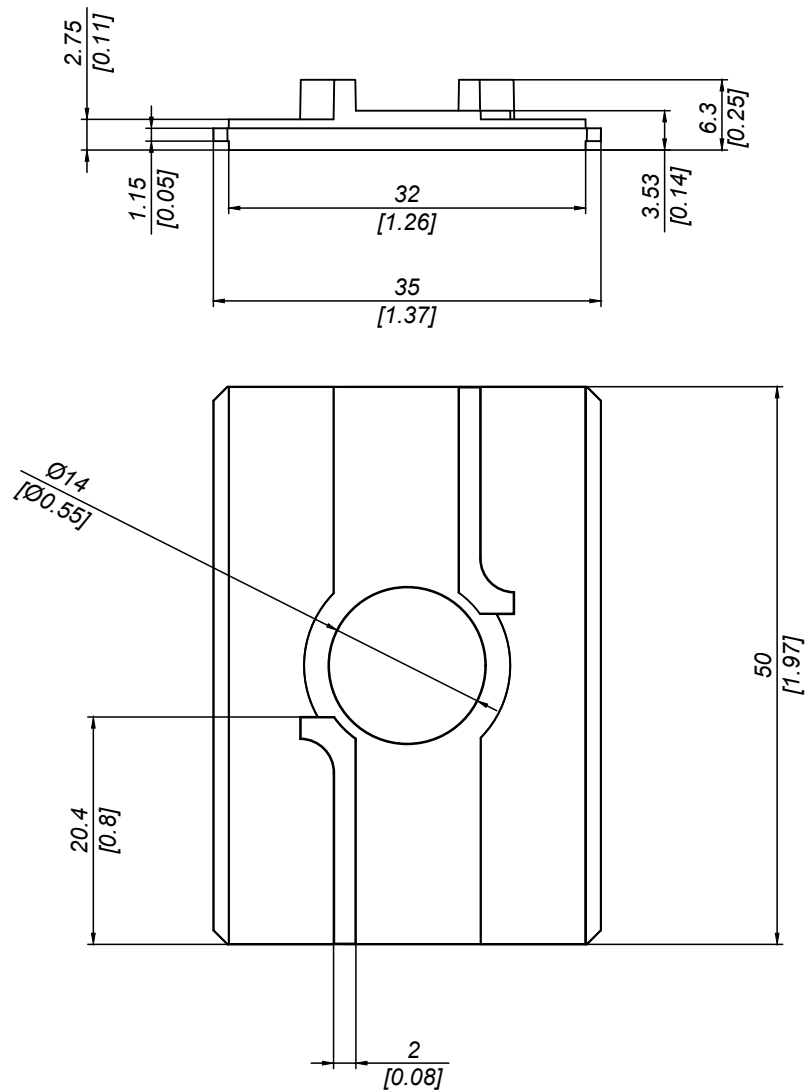

DESCRIZIONE		PATTINO SINISTRO IN NYLON		 alu profiles & components	
DESCRIPTION		NYLON LEFT SPACER			
MATERIALE MATERIAL	PA6+30% F.V. PA6+30% G.F.	TRATTAMENTO TREATMENT	--	SCALA SCALE	2:1
PESO TEORICO THEORETICAL WEIGHT	-- kg -- lbs	NORMA TOLLERANZA STANDARD TOLERANCE	--	DATA DATE	27/04/2018
				CODICE CODE	NG003 G-50
				FORMATO SIZE	A3
					

Questo disegno è di proprietà riservata alla ditta PRO-LAM ALLUMINIO s.r.l. A termini di legge è assolutamente vietato riprodurre o comunicare a terzi il contenuto del presente disegno. This drawing is a property of PRO-LAM ALLUMINIO s.r.l. This drawing shall not be reproduced or released to others except as otherwise authorized by PRO-LAM ALLUMINIO s.r.l.





DESCRIZIONE <b>PATTINO DESTRO IN NYLON</b>		 alu profiles & components	
DESCRIPTION <b>NYLON RIGHT SPACER</b>			
MATERIALE MATERIAL	PA6+30% F.V. PA6+30% G.F.	TRATTAMENTO TREATMENT	--
PESO TEORICO THEORETICAL WEIGHT	-- kg -- lbs	NORMA TOLLERANZA STANDARD TOLERANCE	--
SCALA SCALE		2:1	DATA DATE
CODICE CODE		NG002 G-50	FORMATO SIZE
		A3	

Questo disegno è di proprietà riservata alla ditta PRO-LAM ALLUMINIO s.r.l. A termini di legge è assolutamente vietato riprodurre o comunicare a terzi il contenuto del presente disegno. This drawing is a property of PRO-LAM ALLUMINIO s.r.l. This drawing shall not be reproduced or released to others except as otherwise authorized by PRO-LAM ALLUMINIO s.r.l.

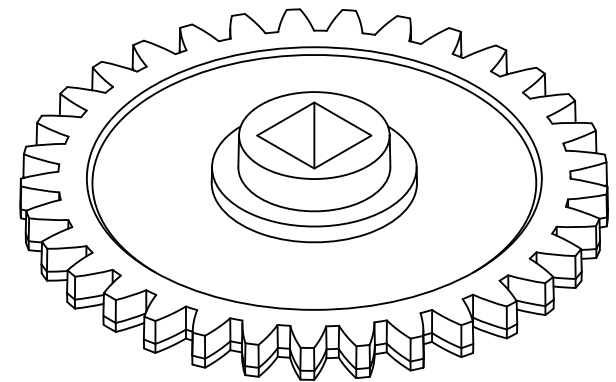
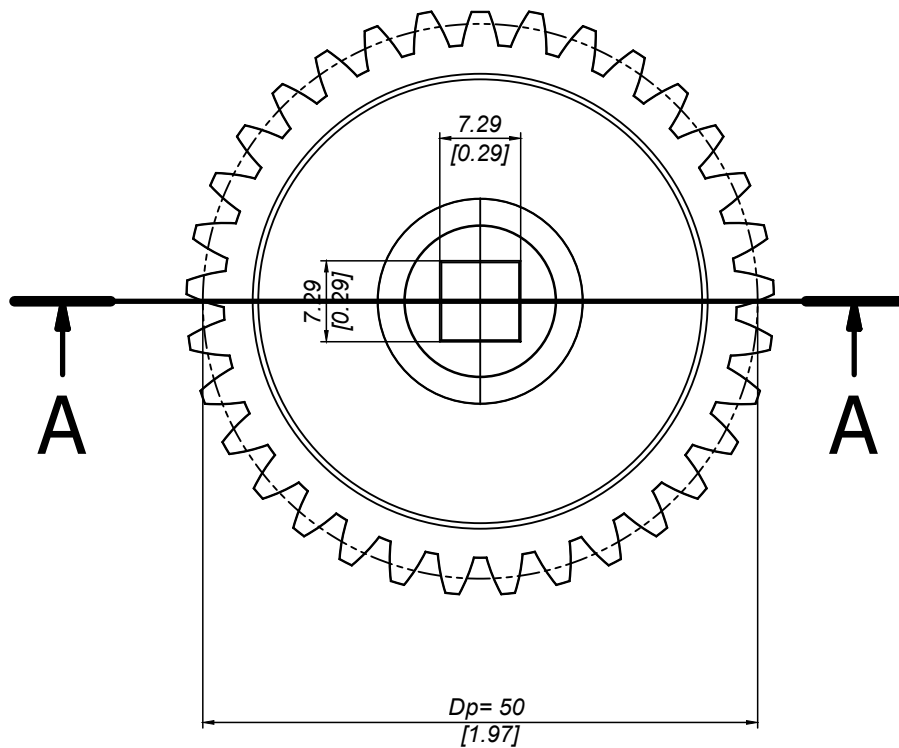
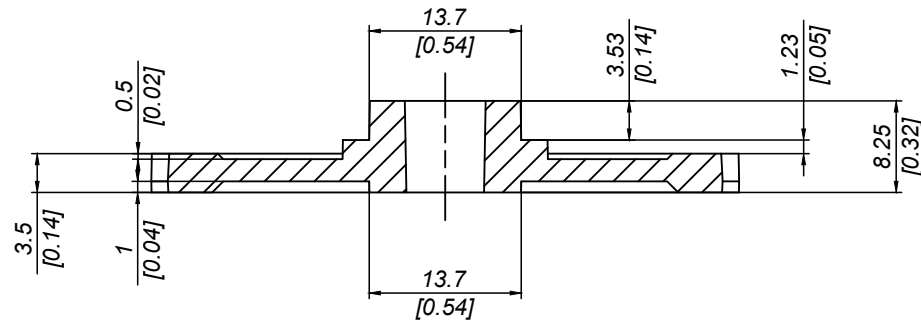
# A-A ( 1 : 1 )



INGRANAGGIO IN NYLON		 alu profiles & components	
DESCRIPTION NYLON GEAR			
MATERIALE MATERIAL	PA6+30% F.V. PA6+30% G.F.	TRATTAMENTO TREATMENT	--
PESO TEORICO THEORETICAL WEIGHT	-- kg -- lbs	NORMA TOLLERANZA STANDARD TOLERANCE	--
SCALA SCALE	2:1	DATA DATE	27/04/2018
CODICE CODE		FORMATO SIZE	
NG004 G-50		A3 	

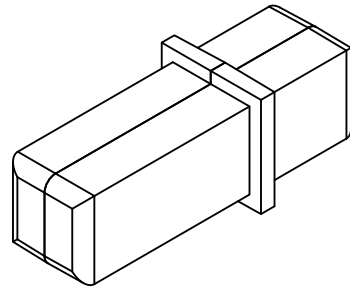
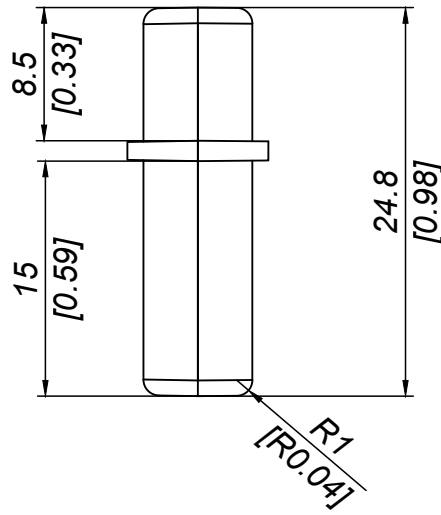
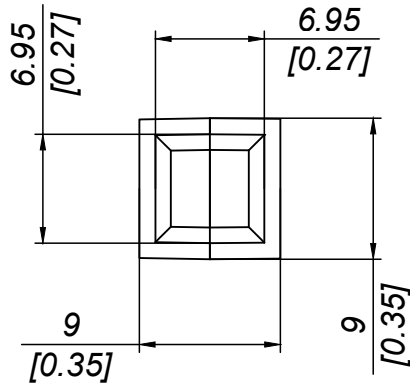

DESCRIZIONE

PERNO IN NYLON

DESCRIPTION

NYLON PIN

MATERIALE  
MATERIAL PA6+30% F.V.  
PA6+30% G.F.

TRATTAMENTO  
TREATMENT --

PESO TEORICO  
THEORETICAL WEIGHT -- kg  
-- lb

NORMA TOLLERANZA  
STANDARD TOLLERANCE --

SCALA  
SCALE 2:1

DATA  
DATE 27/04/2018

CODICE  
CODE NG005 G-50

FORMATO  
SIZE A4

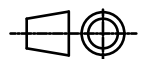

Questo disegno è di proprietà riservata alla ditta PRO-LAM ALLUMINIO s.r.l. A termini di legge è assolutamente vietato riprodurre o comunicare a terzi il contenuto del presente disegno. This drawing is a property of PRO-LAM ALLUMINIO s.r.l. This drawing shall not be reproduced or released to others except as otherwise authorized by PRO-LAM ALLUMINIO s.r.l.

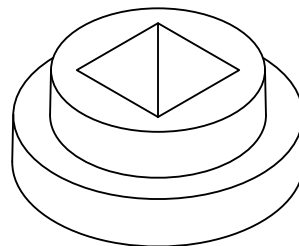
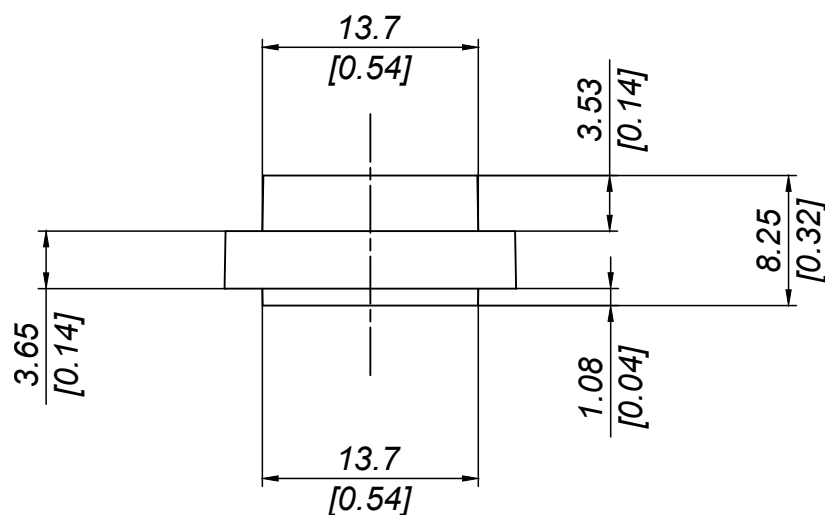
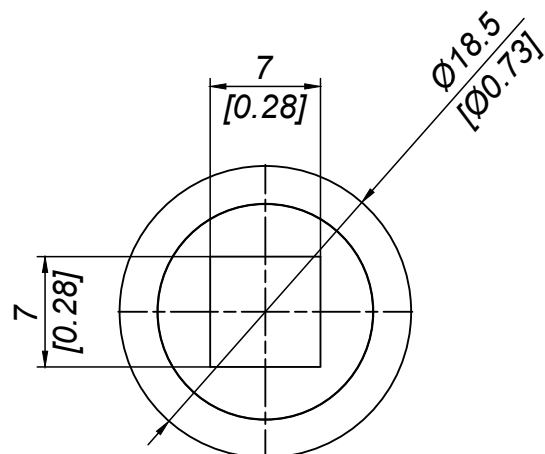

DESCRIZIONE

BOCCOLA IN NYLON

DESCRIPTION

NYLON BUSH



MATERIALE  
MATERIAL PA6+30% F.V.  
PA6+30% G.F.

TRATTAMENTO  
TREATMENT --

SCALA  
SCALE 2:1

DATA  
DATE 27/04/2018

PESO TEORICO  
THEORETICAL WEIGHT -- kg  
-- lb

NORMA TOLLERANZA  
STANDARD TOLLERANCE --

CODICE  
CODE NG006 G-50

FORMATO  
SIZE A4

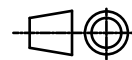

Questo disegno è di proprietà riservata alla ditta PRO-LAM ALLUMINIO s.r.l. A termini di legge è assolutamente vietato riprodurre o comunicare a terzi il contenuto del presente disegno.  
This drawing is a property of PRO-LAM ALLUMINIO s.r.l. This drawing shall not be reproduced or released to others except as otherwise authorized by PRO-LAM ALLUMINIO s.r.l.