

Q.TÀ SCATOLA PACKAGE Q.TY	50
PESO SCATOLA PACKAGE WEIGHT	2 kg 4.41 lbs
DIMENSIONI SCATOLA PACKAGE DIMENSION	48x30x13 cm 7.09x9.84x5.51 inches

DIMENSIONI FORO DA ESEGUIRE NELLA LAMIERA

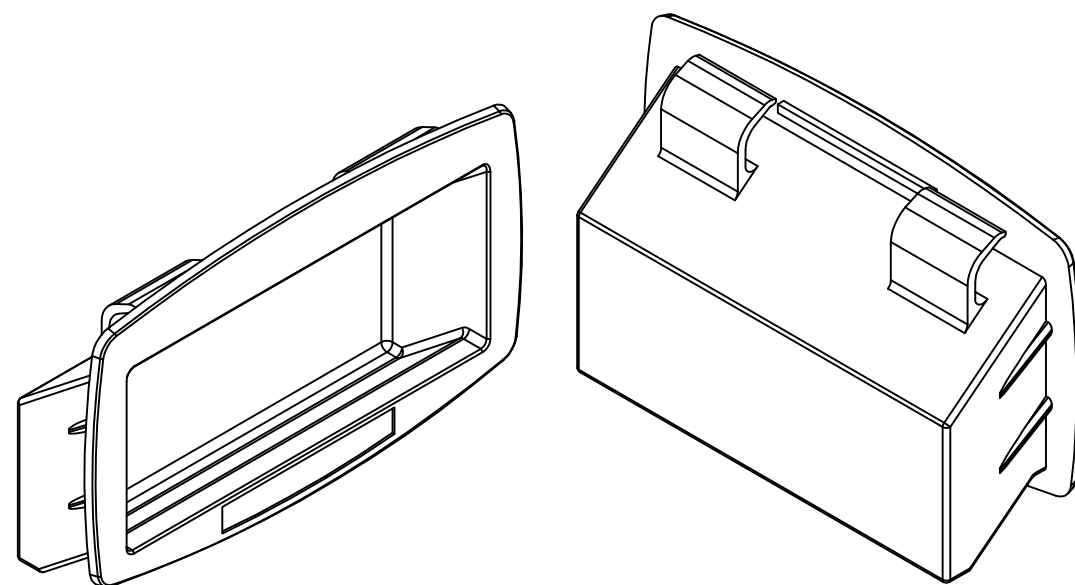
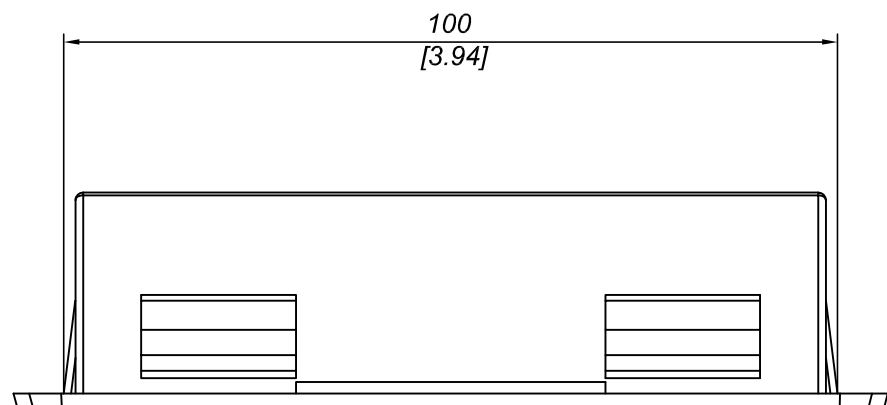
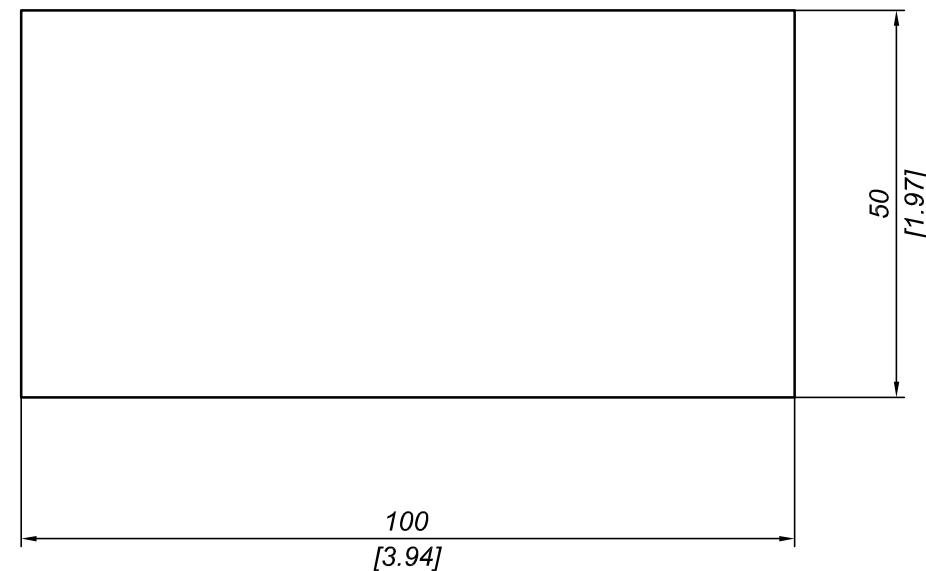
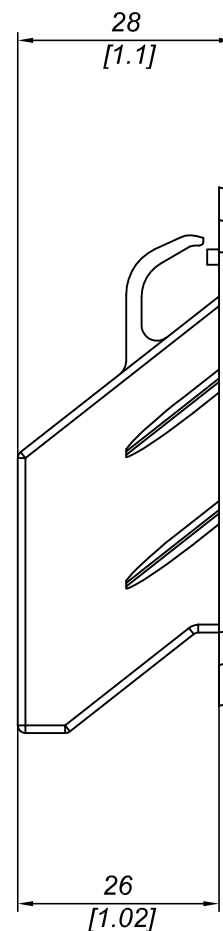
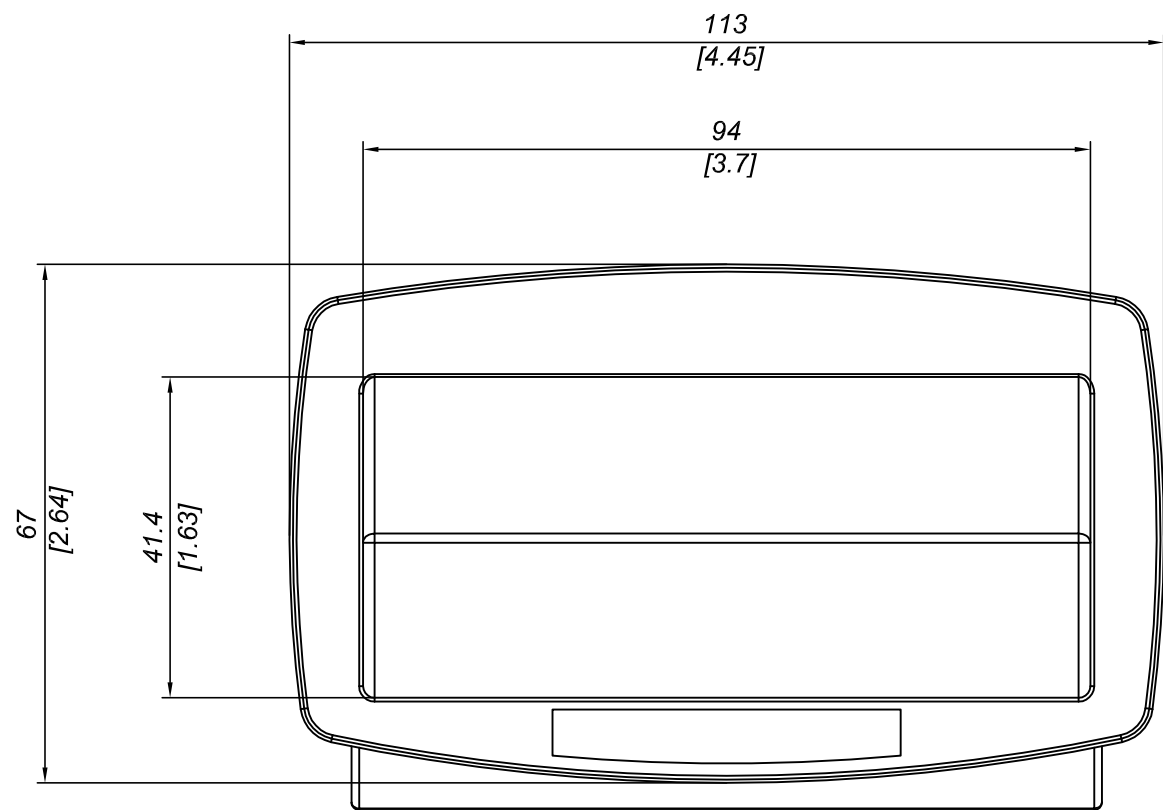

DESCRIZIONE MANIGLIA INCASSATA NEL PANNELLO		DESCRIZIONE HANDLE IN LINE WITH THE PANEL	
MATERIALE MATERIAL	PA6+30%G.F.	TRATTAMENTO TREATMENT	--
PESO TEORICO THEORETICAL WEIGHT	-- kg -- lbs	NORMA TOLLERANZA STANDARD TOLERANCE	--

<b>PRO-LAM</b> s.r.l.		<b>ALLUMINIO</b>	
SCALA SCALE	1:1	DATA DATE	2009/07/18
CODICE CODE	N100x50x0.8	FORMATO SIZE	A3

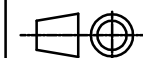

Questo disegno è di proprietà riservata alla ditta PRO-LAM ALLUMINIO s.r.l. A termini di legge è assolutamente vietato riprodurre o comunicare a terzi il contenuto del presente disegno. This drawing is a property of PRO-LAM ALLUMINIO s.r.l. This drawing shall not be reproduced or released to others except as otherwise authorized by PRO-LAM ALLUMINIO s.r.l.