

Q.TÀ SCATOLA PACKAGE Q.TY	50
PESO SCATOLA PACKAGE WEIGHT	3 kg 6.615 lbs
DIMENSIONI SCATOLA PACKAGE DIMENSION	38x12x15 cm 14.96x43.72x53.9 inches

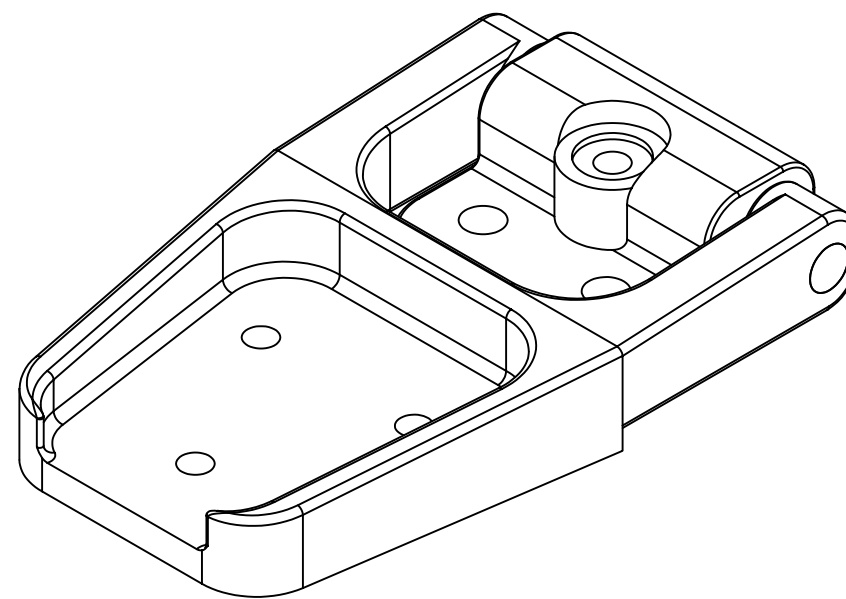
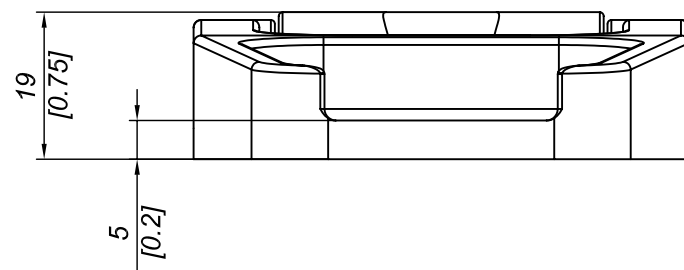
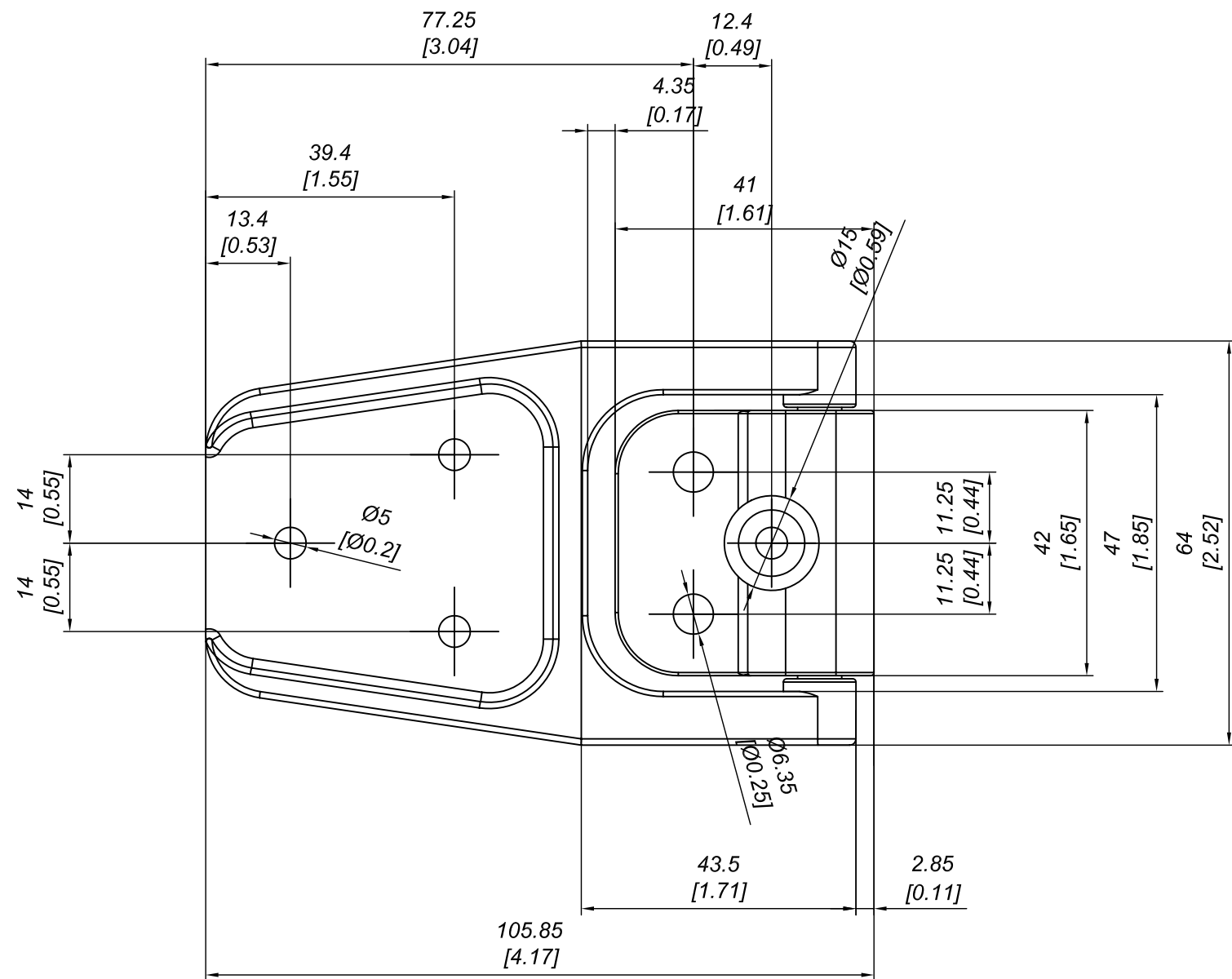

DESCRIZIONE CERNIERA CON FORO DEL PERNO TONDO			
DESCRIPTION HINGE WITH ROUND HOLE OF THE PIN			
MATERIALE MATERIAL	TRATTAMENTO TREATMENT	SCALA SCALE	DATA DATE
PA6+30%G.F.	--	1:1	2009/07/18
PESO TEORICO THEORETICAL WEIGHT	NORMA TOLLERANZA STANDARD TOLERANCE	CODICE CODE	FORMATO SIZE
-- kg -- lb	--	N152	A3

Questo disegno è di proprietà riservata alla ditta PRO-LAM ALLUMINIO s.r.l. A termini di legge è assolutamente vietato riprodurre o comunicare a terzi il contenuto del presente disegno. This drawing is a property of PRO-LAM ALLUMINIO s.r.l. This drawing shall not be reproduced or released to others except as otherwise authorized by PRO-LAM ALLUMINIO s.r.l.