

Q.TÀ SCATOLA PACKAGE Q.TY	100 pcs
PESO SCATOLA PACKAGE WEIGHT	8 kg 17.66 lb
DIMENSIONI SCATOLA PACKAGE DIMENSION	18x25x14 cm 7.09x9.84x5.51 inches

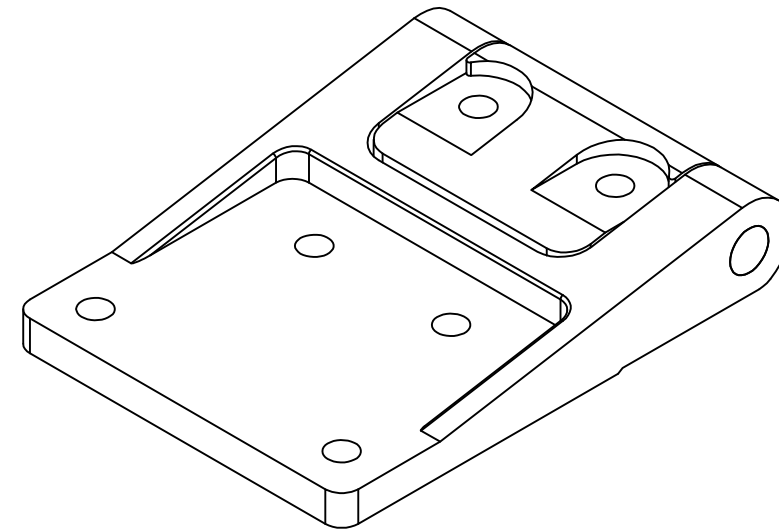
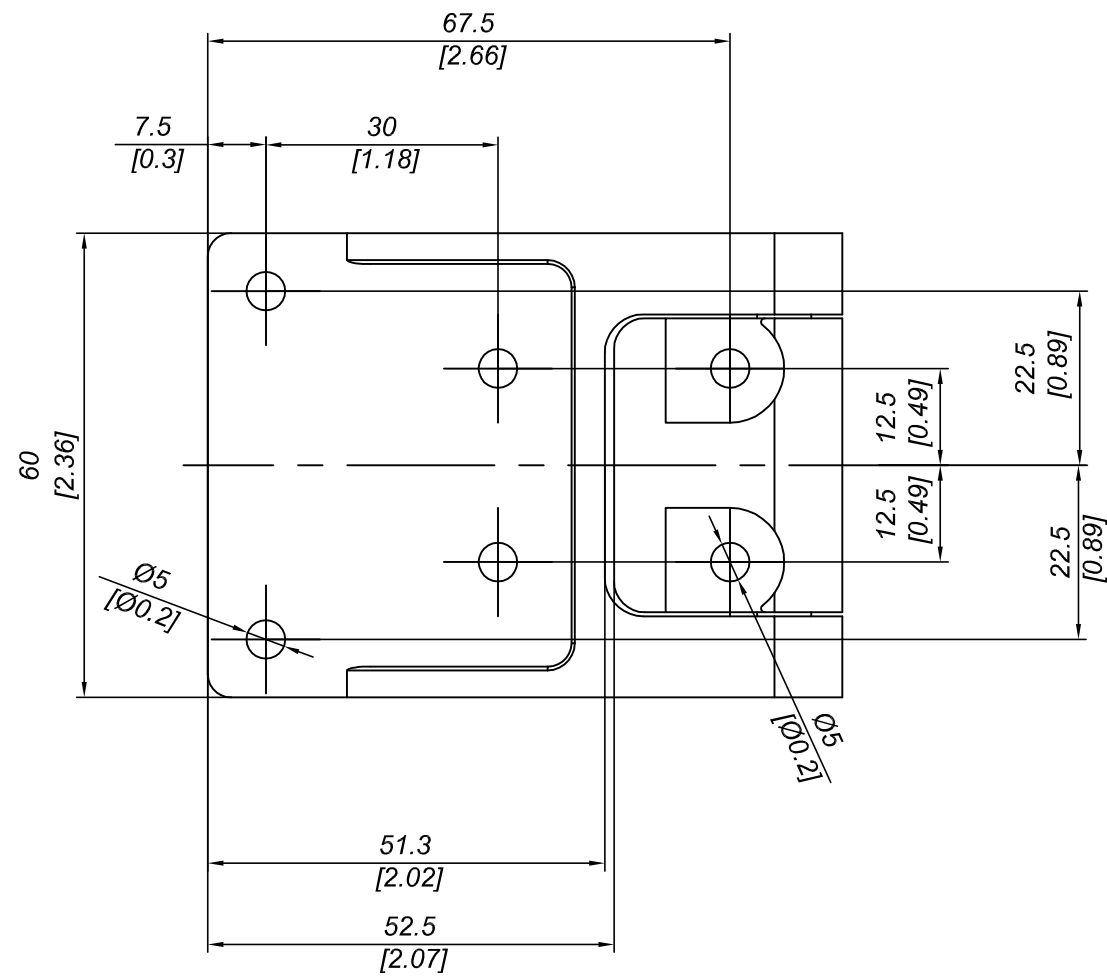
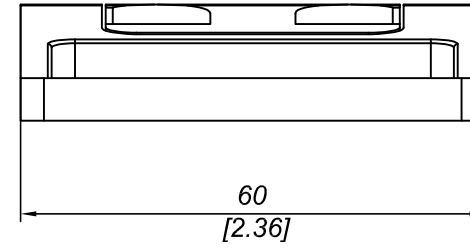
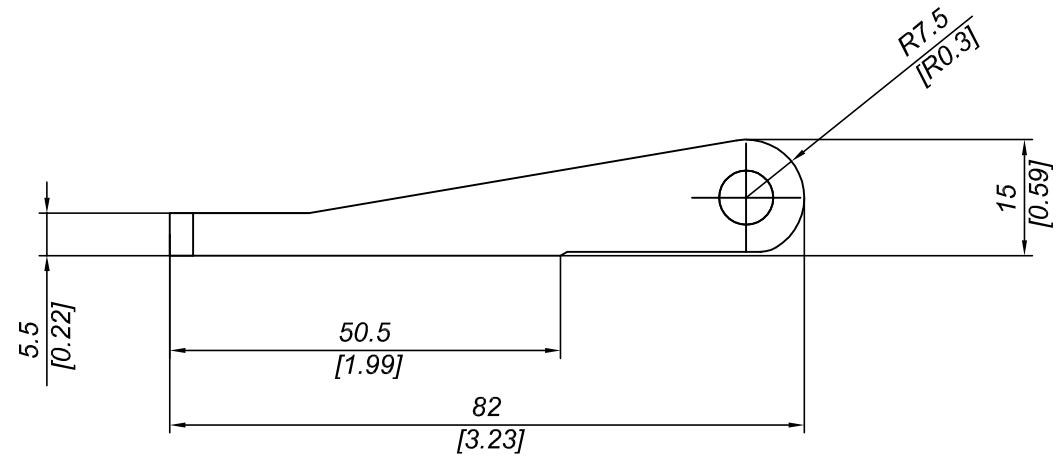

DESCRIZIONE CERNIERA N 153		PRO-LAM s.r.l. ALLUMINIO	
DESCRIPTION NYLON HINGE N 153			
MATERIALE MATERIAL PA6 30 % FV	TRATTAMENTO TREATMENT -----	SCALA SCALE 1:1	DATA DATE 2009/07/18
PESO TEORICO THEORETICAL WEIGHT -- kg -- lb	NORMA TOLLERANZA STANDARD TOLERANCE --	CODICE CODE N 153	FORMATO SIZE A3

Questo disegno è di proprietà riservata alla ditta PRO-LAM ALLUMINIO s.r.l. A termini di legge è assolutamente vietato riprodurre o comunicare a terzi il contenuto del presente disegno. This drawing is a property of PRO-LAM ALLUMINIO s.r.l. This drawing shall not be reproduced or released to others except as otherwise authorized by PRO-LAM ALLUMINIO s.r.l.