

Q.TÀ SCATOLA PACKAGE Q.TY	200 pcs
PESO SCATOLA PACKAGE WEIGHT	2 kg 4.41 lbs
DIMENSIONI SCATOLA PACKAGE DIMENSION	18x25x14 cm 7.09x9.84x5.51 inches

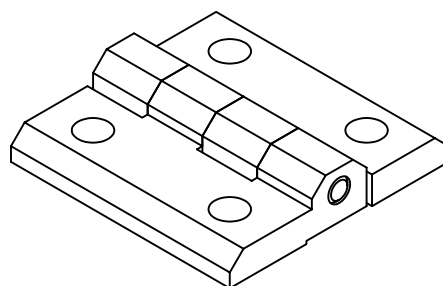

DESCRIZIONE CERNIERA N40x40	
DESCRIPTION HINGE N40x40	
MATERIALE MATERIAL PA6+30%G.F.	TRATTAMENTO TREATMENT --
PESO TEORICO THEORETICAL WEIGHT -- kg -- lb	NORMA TOLLERANZA STANDARD TOLERANCE --

PRO-LAM s.r.l.	
ALLUMINIO	
SCALA SCALE 1:1	DATA DATE 2009/07/18
CODICE CODE N40x40	FORMATO SIZE A4

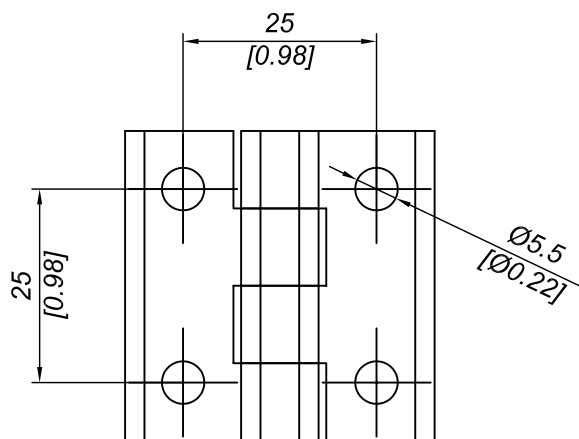
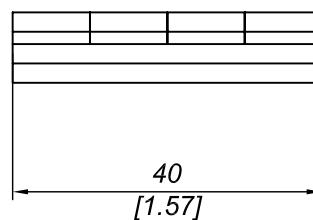
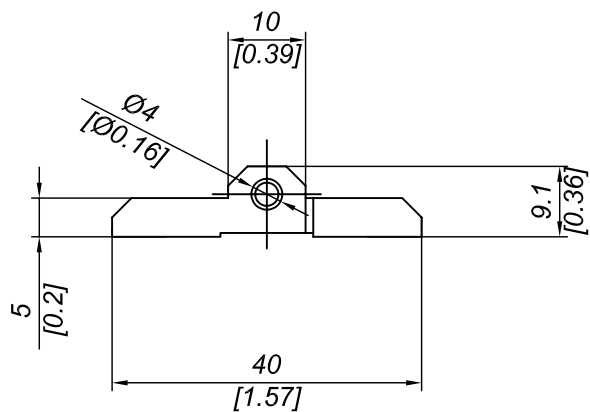
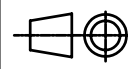

Questo disegno è di proprietà riservata alla ditta PRO-LAM ALLUMINIO s.r.l. A termini di legge è assolutamente vietato riprodurre o comunicare a terzi il contenuto del presente disegno. This drawing is a property of PRO-LAM ALLUMINIO s.r.l. This drawing shall not be reproduced or released to others except as otherwise authorized by PRO-LAM ALLUMINIO s.r.l.