

Q.TÀ SCATOLA PACKAGE Q.TY	200
PESO SCATOLA PACKAGE WEIGHT	4 kg 13.23 lbs
DIMENSIONI SCATOLA PACKAGE DIMENSION	22x35x22 cm 8.66x13.78x8.66 inches

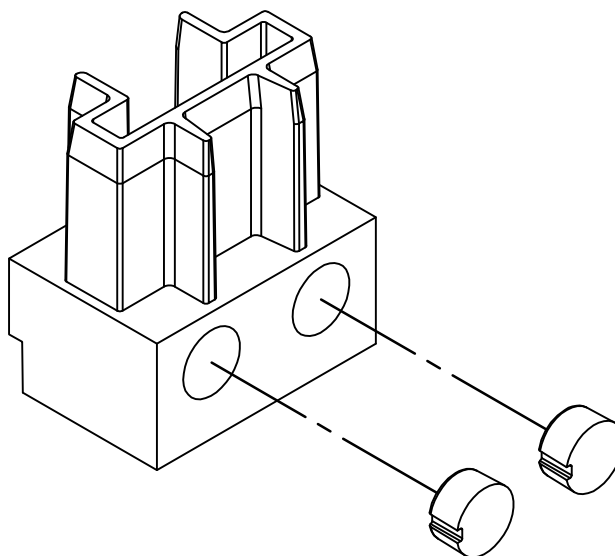
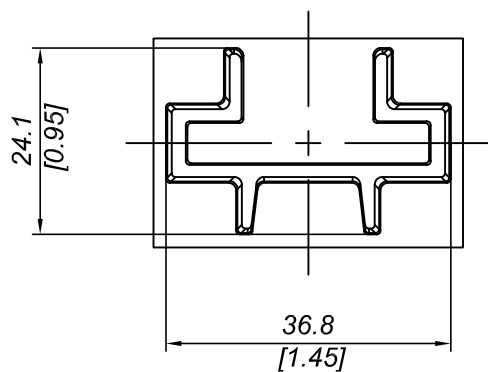
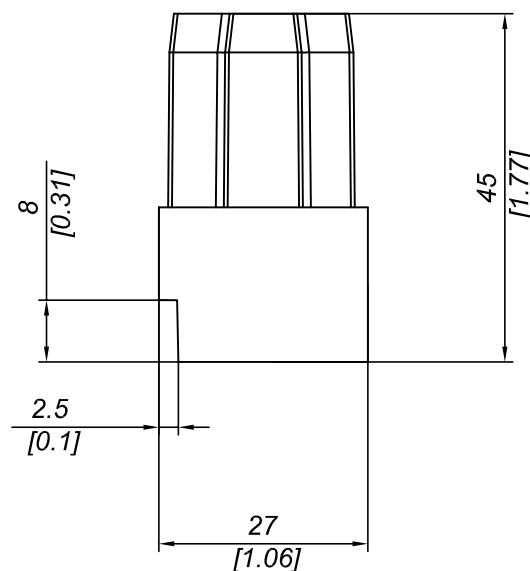
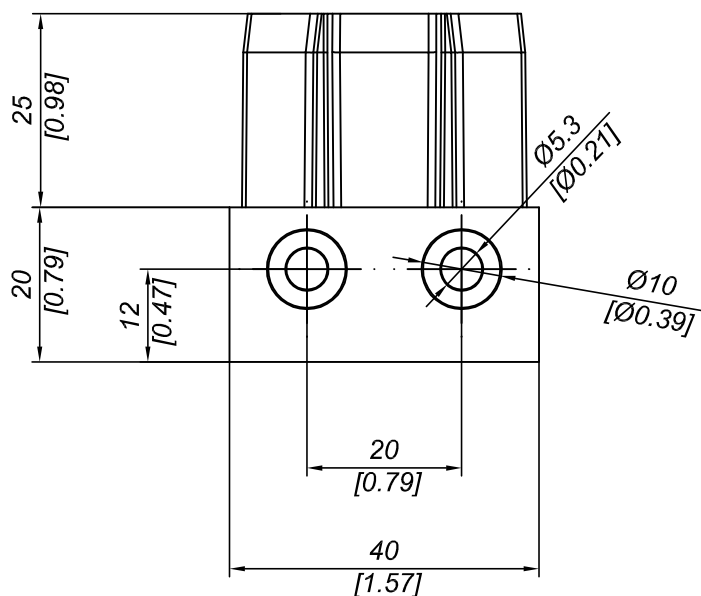

DESCRIZIONE ANGOLO IN NYLON PER OMEGA
40 mm

DESCRIPTION NYLON JOINT FOR OMEGA
PROFILE 40 mm

PRO-LAM s.r.l.

ALLUMINIO

MATERIALE
MATERIAL PA6+30%G.F.

TRATTAMENTO
TREATMENT --

SCALA
SCALE 1:1

DATA
DATE 2009/07/18

PESO TEORICO
THEORETICAL WEIGHT -- kg
-- lbs

NORMA TOLLERANZA
STANDARD TOLERANCE --

CODICE
CODE N40JP

FORMATO
SIZE A4

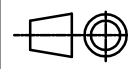

Questo disegno è di proprietà riservata alla ditta PRO-LAM ALLUMINIO s.r.l. A termini di legge è assolutamente vietato riprodurre o comunicare a terzi il contenuto del presente disegno. This drawing is a property of PRO-LAM ALLUMINIO s.r.l. This drawing shall not be reproduced or released to others except as otherwise authorized by PRO-LAM ALLUMINIO s.r.l.