

Q.TÀ SCATOLA PACKAGE Q.TY	100
PESO SCATOLA PACKAGE WEIGHT	5 kg 11.025 lbs
DIMENSIONI SCATOLA PACKAGE DIMENSION	22x35x22 cm 8.66x13.78x8.66 inches

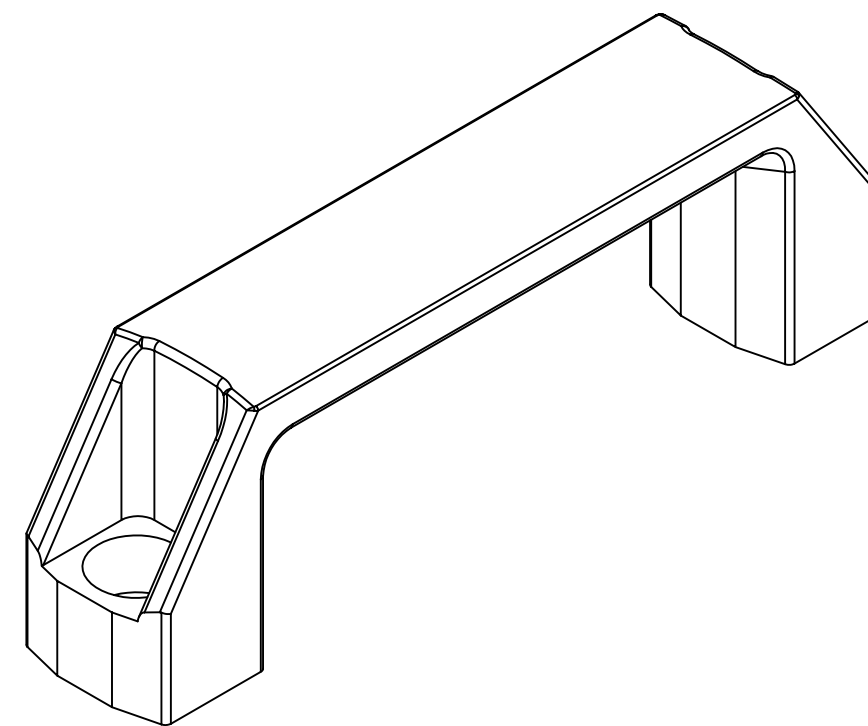
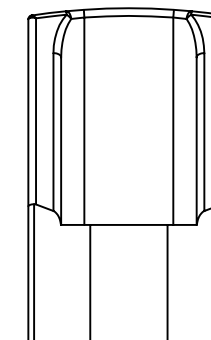
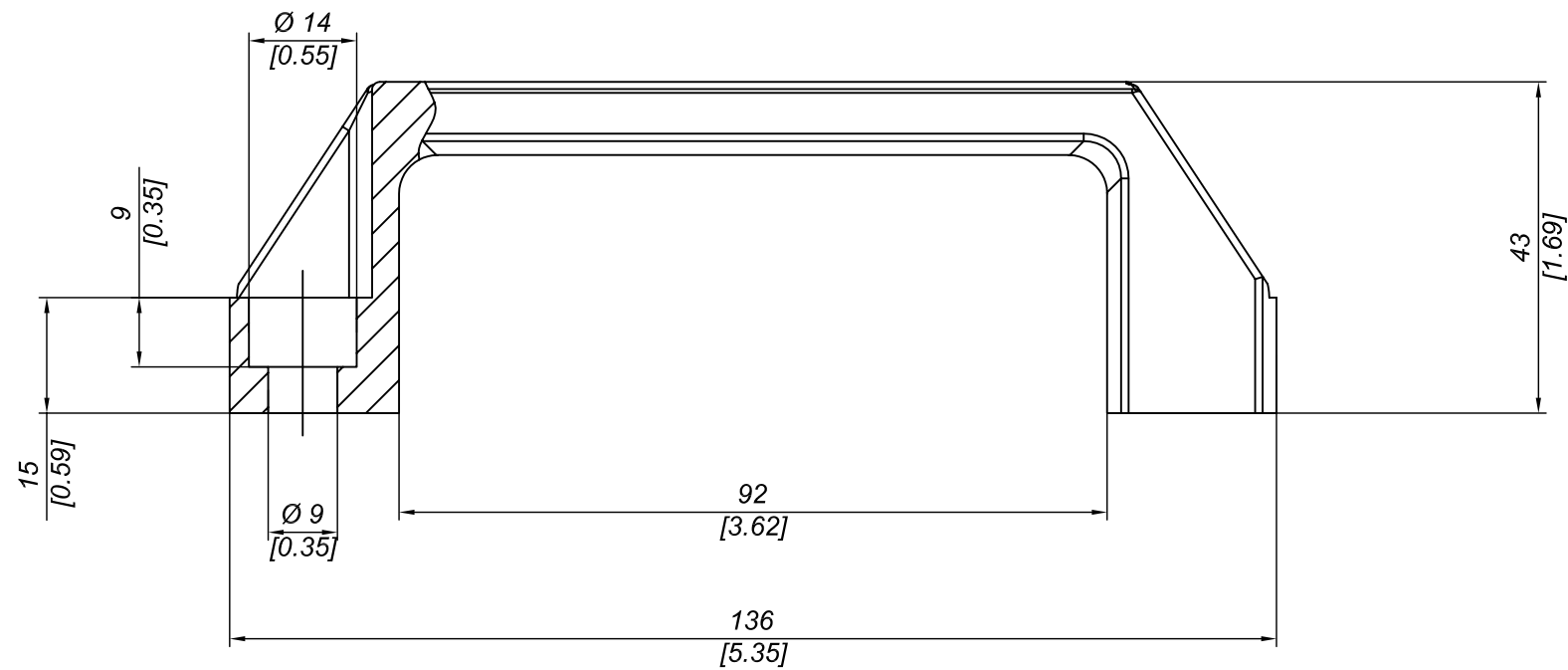

DESCRIZIONE MANIGLIA N62		PRO-LAM s.r.l. ALLUMINIO	
DESCRIPTION HANDLE N62			
MATERIALE MATERIAL	PA6+30%G.F.	TRATTAMENTO TREATMENT	--
PESO TEORICO THEORETICAL WEIGHT	-- kg -- lb	NORMA TOLLERANZA STANDARD TOLLERANCE	--
		SCALA SCALE	1:1
		DATA DATE	2009/07/18
		CODICE CODE	N62
		FORMATO SIZE	A3

Questo disegno è di proprietà riservata alla ditta PRO-LAM ALLUMINIO s.r.l. A termini di legge è assolutamente vietato riprodurre o comunicare a terzi il contenuto del presente disegno. This drawing is a property of PRO-LAM ALLUMINIO s.r.l. This drawing shall not be reproduced or released to others except as otherwise authorized by PRO-LAM ALLUMINIO s.r.l.