

Q.TÀ SCATOLA PACKAGE Q.TY	1500
PESO SCATOLA PACKAGE WEIGHT	1 kg 2.205 lbs
DIMENSIONI SCATOLA PACKAGE DIMENSION	18x25x14 cm 7.09x9.84x5.51 inches

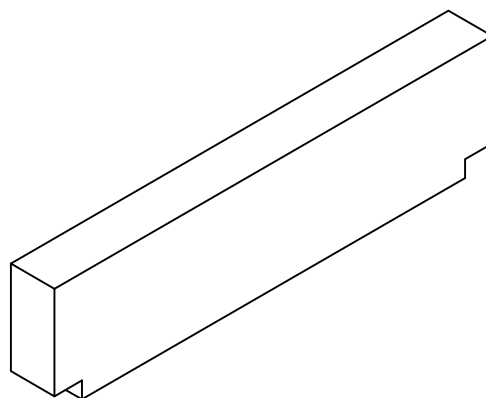

DESCRIZIONE <b>SPESSORE PER SERRANDA</b>	
DESCRIPTION <b>THICKNESS FOR DAMPER</b>	
MATERIALE MATERIAL <b>PA6+30%G.F.</b>	TRATTAMENTO TREATMENT --
PESO TEORICO THEORETICAL WEIGHT -- kg -- lb	NORMA TOLLERANZA STANDARD TOLERANCE --

SCALA SCALE <b>2:1</b>	DATA DATE <b>2009/07/18</b>
CODICE CODE <b>N850</b>	FORMATO SIZE <b>A4</b>

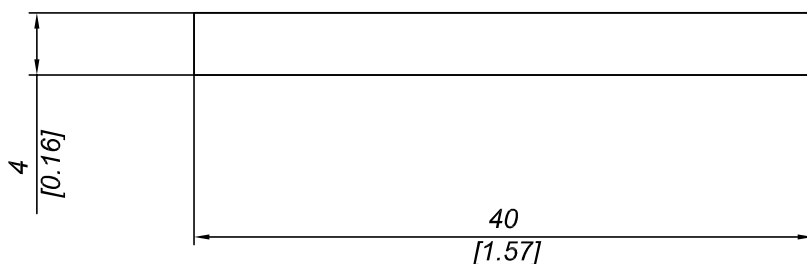
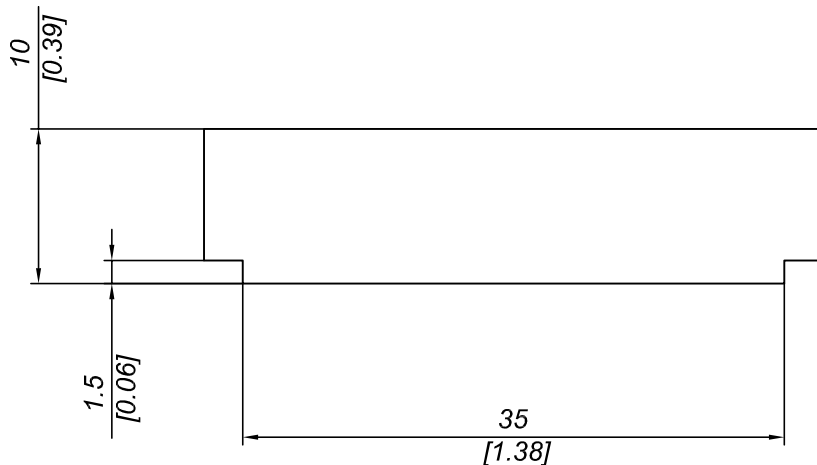
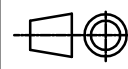

Questo disegno è di proprietà riservata alla ditta PRO-LAM ALLUMINIO s.r.l. A termini di legge è assolutamente vietato riprodurre o comunicare a terzi il contenuto del presente disegno. This drawing is a property of PRO-LAM ALLUMINIO s.r.l. This drawing shall not be reproduced or released to others except as otherwise authorized by PRO-LAM ALLUMINIO s.r.l.