

Q.TÀ SCATOLA PACKAGE Q.TY	1000
PESO SCATOLA PACKAGE WEIGHT	3 kg 6.615 lbs
DIMENSIONI SCATOLA PACKAGE DIMENSION	22x35x22 cm 8.66x13.78x8.66 inches

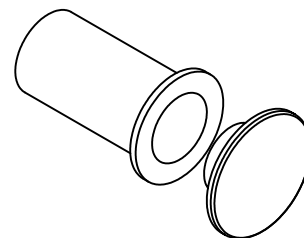
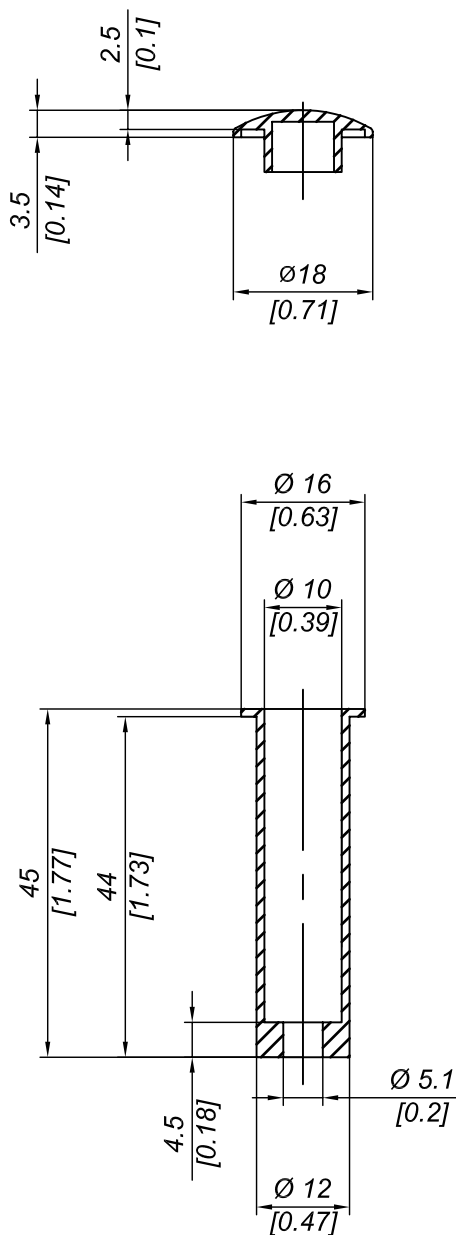

DESCRIZIONE
BUSSOLA GUIDAVITE (45 mm)

DESCRIPTION
SCREW-GUIDE BUSHINGS (45 mm)

PRO-LAM s.r.l.

ALLUMINIO

MATERIALE
MATERIAL
PA6+30%G.F.

TRATTAMENTO
TREATMENT
--

SCALA
SCALE
1:1

DATA
DATE
2009/07/18

PESO TEORICO
THEORETICAL WEIGHT
-- kg
-- lb

NORMA TOLLERANZA
STANDARD TOLERANCE
--

CODICE
CODE
N871

FORMATO
SIZE
A4

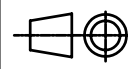

Questo disegno è di proprietà riservata alla ditta PRO-LAM ALLUMINIO s.r.l. A termini di legge è assolutamente vietato riprodurre o comunicare a terzi il contenuto del presente disegno. This drawing is a property of PRO-LAM ALLUMINIO s.r.l. This drawing shall not be reproduced or released to others except as otherwise authorized by PRO-LAM ALLUMINIO s.r.l.